

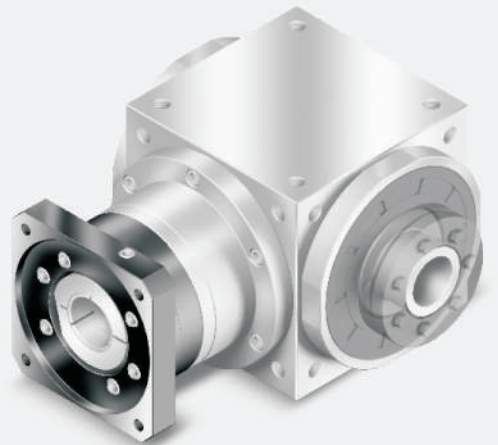

LINEAR MOTION

HIGH PRECISION SPIRAL BEVEL GEARBOX

AT / ATB Series

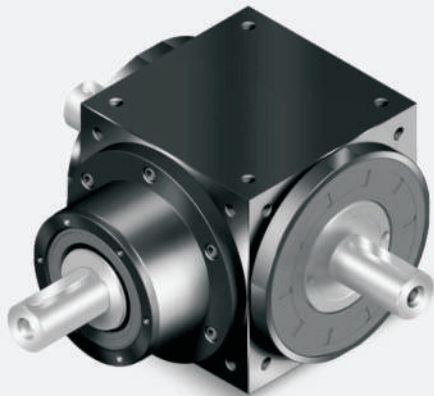
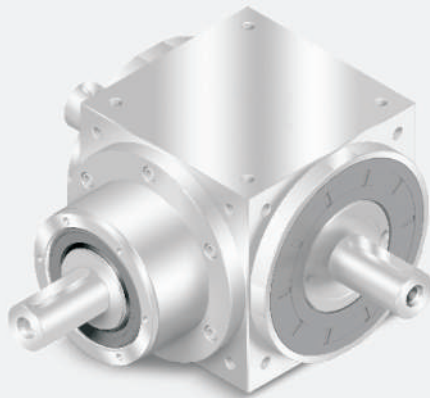

Stainless - AT

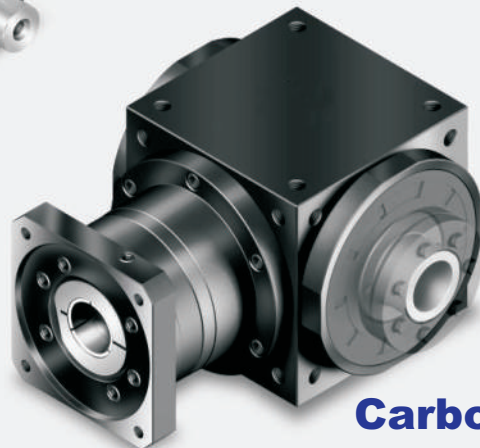

Carbon Steel - ATB

Gearbox Series - AT / ATB

► Features:

Various housing design

Stainless - AT

Carbon Steel - ATB

Various output options

High torque

High efficiency

Long service life

Reduced backlash

Maintenance free

Flexible mounting dimensions

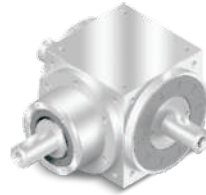

AT-L/-L1/-R1

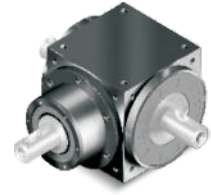

ATB-L/-L1/-R1

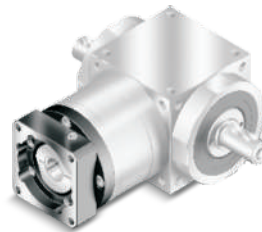

AT-FL/-FL1/-FR1

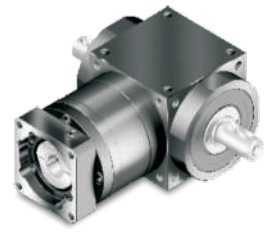

ATB-FL/-FL1/-FR1

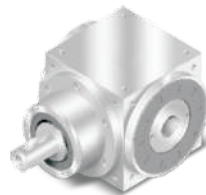

AT-H/-C



ATB-H/-C



AT-FH/-FC



ATB-FH/-FC



AT-4M/-LM/-RM



ATB-4M/-LM/-RM

Ordering code

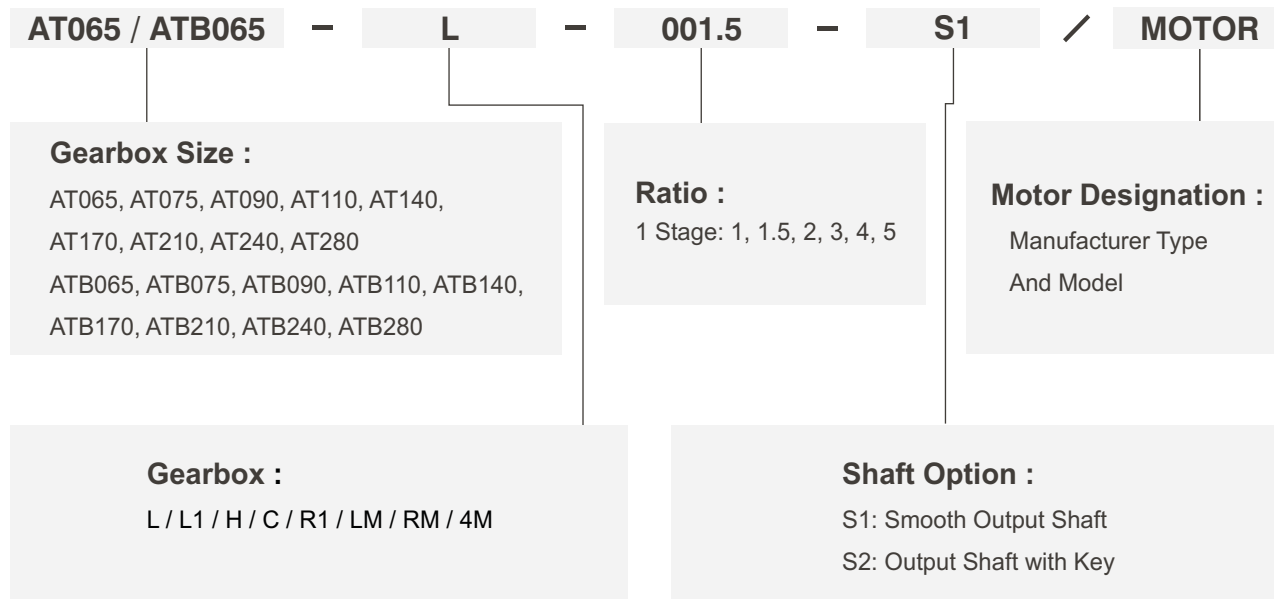

Ordering Example: AT065-L-001.5-S1 / SIEMENS 1FK6 032-6AK71
ATB065-L-001.5-S1 / SIEMENS 1FK6 032-6AK71

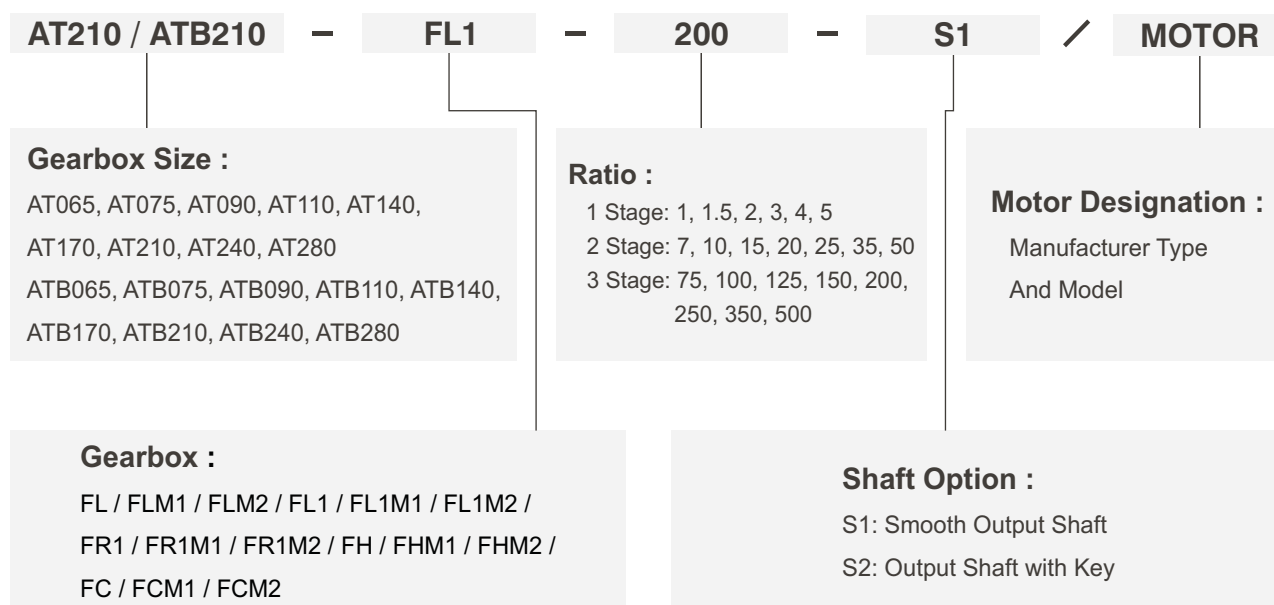

Ordering Example: AT210-FL1-200-S1 / SIEMENS 1FK6 032-6AK71
ATB210-FL1-200-S1 / SIEMENS 1FK6 032-6AK71

Rotate Directions of AT / ATB Series

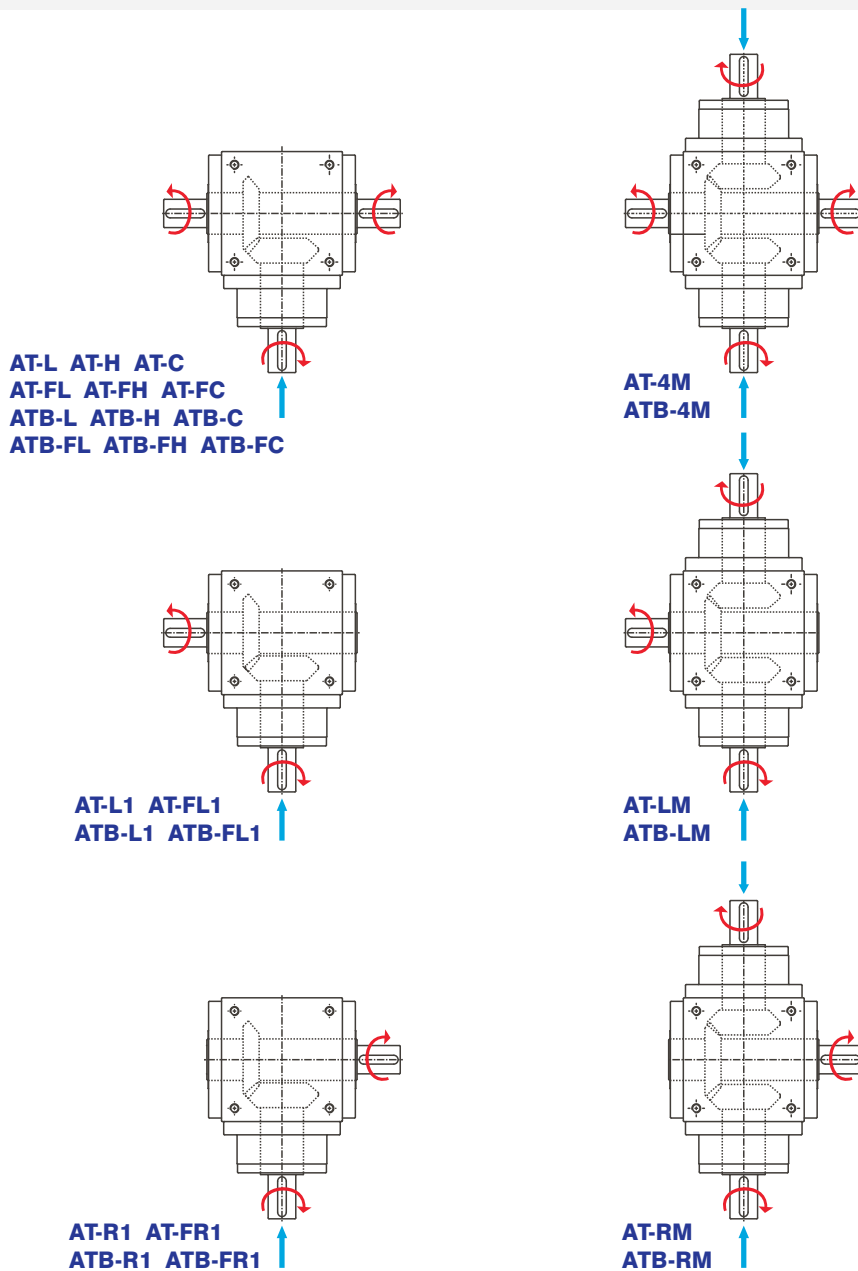

Accessories - Shrink Disc Power Lock

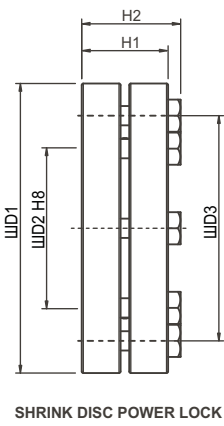

Diameter	Tolerance
≤ 30	H6 / j6
> 30 ~ 50	H6 / h6
> 50 ~ 80	H6 / g6

* For surface roughness Ra3.2 um

Model No. AT/ATB	Shrink disc power lock	D1	D2	D3	H1	H2	Screw ⁽¹⁾	T _A ⁽²⁾	J	Order Code
							No.x type	Nm	kg-cm ²	
065/075	SSD-d16xdw14	41	16	26	15	18.5	5xM5	4	0.3	SSD-16
090	SSD-d22xdw18	50	22	36	19.5	23	6xM5	4	0.8	SSD-22
110	SSD-d25xdw22	50	25	38	19.5	23	6xM5	4	0.8	SSD-25
140	SSD-d44xdw32	80	44	61	25.5	29.5	7xM6	12	6.4	SSD-44
170	SSD-d50xdw40	90	50	70	27.5	31.5	8xM6	12	11.2	SSD-50
210	SSD-d62xdw50	110	62	86	30.5	34.5	10xM6	12	26.5	SSD-62
240	SSD-d68xdw55	115	68	86	30.5	34.5	10xM6	12	30.9	SSD-68
280	SSD-d75xdw60	138	75	100	32.5	38	7xM8	30	67.1	SSD-75

(1) 10.9 Class, DIN 931 (2) Tightening Torque

Specifications

AT / ATB Shaft Type Series

Gearbox Performance (The performance and specification of ATB series are identical to AT series.)

Model No.	Stage	Ratio ^A	AT065 L	AT075 L	AT090 L	AT110 L	AT140 L	AT170 L	AT210 L	AT240 L	AT280 L	
			AT065 L1	AT075 L1	AT090 L1	AT110 L1	AT140 L1	AT170 L1	AT210 L1	AT240 L1	AT280 L1	
			AT065 H	AT075 H	AT090 H	AT110 H	AT140 H	AT170 H	AT210 H	AT240 H	AT280 H	
			AT065 C	AT075 C	AT090 C	AT110 C	AT140 C	AT170 C	AT210 C	AT240 C	AT280 C	
			AT065 R1	AT075 R1	AT090 R1	AT110 R1	AT140 R1	AT170 R1	AT210 R1	AT240 R1	AT280 R1	
			AT065 LM	AT075 LM	AT090 LM	AT110 LM	AT140 LM	AT170 LM	AT210 LM	AT240 LM	AT280 LM	
			AT065 RM	AT075 RM	AT090 RM	AT110 RM	AT140 RM	AT170 RM	AT210 RM	AT240 RM	AT280 RM	
			AT065 4M	AT075 4M	AT090 4M	AT110 4M	AT140 4M	AT170 4M	AT210 4M	AT240 4M	AT280 4M	
Nominal Output Torque T_{2N}	Nm	1	25	45	78	150	360	585	1,300	2,150	3,200	
		1.5	25	45	78	150	360	585	1,300	2,150	3,200	
		2	24	42	68	150	330	544	1,220	2,010	3,050	
		3	18	33	54	120	270	450	1,020	1,650	2,850	
		4	13	28	48	100	224	376	860	1,410	2,300	
		5	12	25	40	85	196	320	740	1,210	2,000	
Max. Acceleration Torque T_{2B}	Nm	1	1~5	1.5 times of Nominal Output Torque								
Max. Acceleration Input Speed n_{1B}	rpm	1	1~5	7,500	6,500	5,500	4,500	3,500	3,000	2,200	2,000	1,700
Standard Backlash ^B	arcmin	1	1~5	≤6	≤6	≤6	≤6	≤6	≤6	≤6	≤6	≤6
Max. Radial Load F_{1B}^C Input d1	N	1	1~5	700	950	1,450	2,100	2,700	3,800	7,800	9,600	10,500
Max. Radial Load F_{2B}^D Output d2	N	1	1~5	900	1,100	1,700	2,700	4,800	6,600	11,500	16,000	18,000
Max. Axial Load F_{1aB}^C Input d1	N	1	1~5	350	425	725	1,050	1,350	1,900	3,900	4,800	5,250
Max. Axial Load F_{2aB}^D Output d2	N	1	1~5	450	550	850	1,350	2,400	3,300	5,750	8,500	9,000
Efficiency η	%	1	1~5	≥ 98%								
Operating Temp	°C	1	1~5	-10 °C ~ 90 °C								
Lubrication				Synthetic lubrication oils								
Noise Level ^E	dB (A)	1	1~5	≤68	≤70	≤74	≤76	≤77	≤78	≤80	≤82	≤83

Gearbox Inertia (The performance and specification of ATB series are identical to AT series.)

Model No.	Stage	Ratio ^A	AT065 L	AT075 L	AT090 L	AT110 L	AT140 L	AT170 L	AT210 L	AT240 L	AT280 L
			AT065 L1	AT075 L1	AT090 L1	AT110 L1	AT140 L1	AT170 L1	AT210 L1	AT240 L1	AT280 L1
			AT065 H	AT075 H	AT090 H	AT110 H	AT140 H	AT170 H	AT210 H	AT240 H	AT280 H
			AT065 C	AT075 C	AT090 C	AT110 C	AT140 C	AT170 C	AT210 C	AT240 C	AT280 C
			AT065 R1	AT075 R1	AT090 R1	AT110 R1	AT140 R1	AT170 R1	AT210 R1	AT240 R1	AT280 R1
			AT065 LM	AT075 LM	AT090 LM	AT110 LM	AT140 LM	AT170 LM	AT210 LM	AT240 LM	AT280 LM
			AT065 RM	AT075 RM	AT090 RM	AT110 RM	AT140 RM	AT170 RM	AT210 RM	AT240 RM	AT280 RM
			AT065 4M	AT075 4M	AT090 4M	AT110 4M	AT140 4M	AT170 4M	AT210 4M	AT240 4M	AT280 4M
Mass Moments of Inertia J_1	kg · cm ²	1	0.51	1.30	3.16	7.70	23.57	58.99	195.40	369.34	799.12
		1.5	0.64	1.16	2.82	6.74	19.37	49.28	155.45	283.58	595.78
		2	0.44	1.11	2.70	6.31	17.75	45.35	140.24	249.74	511.76
		3	0.43	1.09	2.66	6.17	17.18	44.01	134.95	237.71	483.06
		4	0.43	1.09	2.65	6.13	17.06	43.70	133.58	234.72	476.26
		5	0.43	1.09	2.65	6.12	17.02	43.60	133.14	233.67	473.58

Weight

Model No.	Stage	Ratio ^A	AT065	AT075	AT090	AT110	AT140	AT170	AT210	AT240	AT280
L Series	1	1~5	2.6	4.2	6.8	11.6	19.8	34.8	66.2	98.1	155.7
L1 Series	1	1~5	2.6	4.1	6.7	11.5	19.5	34.2	65.1	96.6	153.4
H Series	1	1~5	2.5	3.9	6.4	11.0	18.1	31.6	60.0	89.4	143.4
C Series	1	1~5	2.8	4.2	6.9	11.4	19.6	33.7	63.3	97.9	149.1
R1 Series	1	1~5	2.6	4.1	6.7	11.5	19.5	34.2	65.1	96.6	153.4
LM Series	1	1	3.5	5.6	9.0	15.2	24.1	42.4	81.4	122.0	190.9
RM Series	1	1	3.5	5.6	9.0	15.2	24.1	42.4	81.4	122.0	190.9
4M Series	1	1	3.5	5.6	9.1	15.4	24.8	42.6	82.5	123.5	193.3

A. Ratio ($i = N_{in} / N_{out}$). AT-LM / RM / 4M offer ratio 1 : 1 only.

B. Backlash is measured at 2% Nominal Torque T_{2N} .

C. Apply to the Input shaft center at n_{1B} .

D. Apply to the output shaft center at n_{1B} .

E. The dB values are measured by gearbox with ratio 5 (1-stage), no loading at 1,500 RPM or at the respective Nominal Input Speed by bigger model size.

By lower ratio and/or higher RPM, the noise level could be 3 to 5 dB higher.

F. One year warranty.

Dimensions (1-stage, Ratio $i=1\sim5$)

AT-L / ATB-L Series

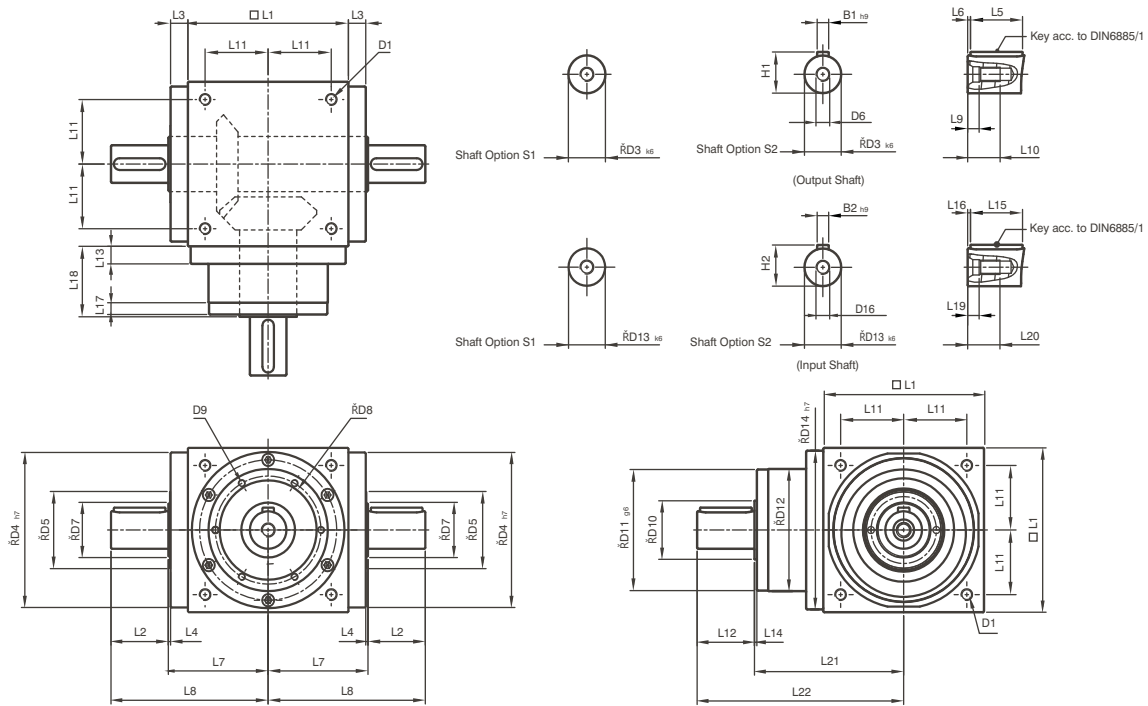

* The dimensions of ATB series are identical to AT series.

[unit: mm]

Dimension	AT065 L	AT075 L	AT090 L	AT110 L	AT140 L	AT170 L	AT210 L	AT240 L	AT280 L
D1	M4	M6	M6	M8	M10	M12	M16	M16	M16
D3 _{k6}	13	16	18	22	32	40	50	55	60
D4 _{h7}	63	73	88	108	135	165	205	235	275
D5	31	35	43	53	68	83	104	124	144
D6	M4	M5	M5	M8	M12	M16	M16	M16	M20
D7	21	22	28	33	47	55	75	85	110
D8	53	62	76	95	92	114	142	160	176
D9	4xM4xL7	4xM5xL8	4xM5xL8	6xM6xL10	6xM6xL10	6xM8xL12.5	6xM8xL12.5	6xM8xL12.5	6xM10xL15
D10	15.4	20.4	25.8	35.8	49.8	59.3	79.3	92.3	102.3
D11 _{g6}	62.9	72.9	87	107	103	127	158	178	198
D12	62	72	86	106	104	128	160	180	200
D13 _{k6}	13	16	18	22	32	40	50	55	60
D14 _{h7}	63	73	88	108	135	165	205	235	275
D16	M4	M5	M5	M8	M12	M16	M16	M16	M20
L1	65	75	90	110	140	170	210	240	280
L2	19.5	30	35	40	50	60	75	85	110
L3	13	14.5	15	15	15	15	20	25	25
L4	2	2	2	2	2	2	2	2	2
L5	16	25	28	32	45	50	70	80	100
L6	2	2.5	3.5	4	2.5	5	2.5	2.5	5
L7	47.5	54	62	72	87	102	127	147	167
L8	67	84	97	112	137	162	202	232	277
L9	4.5	4.8	4.8	7.2	10	12	12	12	15
L10	10	12.5	12.5	19	28	36	36	36	42
L11	27	30	36	44	55	67	85	95	110
L12	19.5	30	35	40	50	60	75	85	110
L13	13	15	15	15	15	15	20	25	25
L14	2	2	2	2	2	2	2	2	2
L15	16	25	28	32	45	50	70	80	100
L16	2	2.5	3.5	4	2.5	5	2.5	2.5	5
L17	6	8	8	8	10	10	10	10	10
L18	43	52.5	55	60	60	70	90	105	120
L19	4.5	4.8	4.8	7.2	10	12	12	12	15
L20	10	12.5	12.5	19	28	36	36	36	42
L21	75.5	90	100	115	130	155	195	225	260
L22	95	120	135	155	180	215	270	310	370
B1 _{h9}	5	5	6	6	10	12	14	16	18
B2 _{h9}	5	5	6	6	10	12	14	16	18
H1	15	18	20.5	24.5	35	43	53.5	59	64
H2	15	18	20.5	24.5	35	43	53.5	59	64

Dimensions (1-stage, Ratio $i=1\sim5$) AT-L1/R1 | ATB-L1/R1 Series

AT-L1

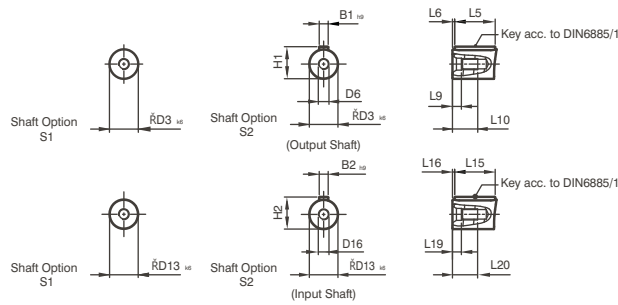
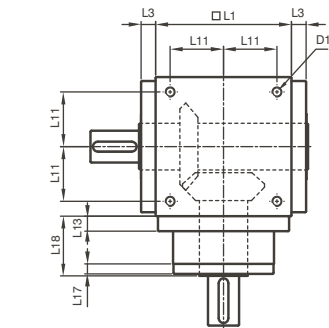

AT-R1

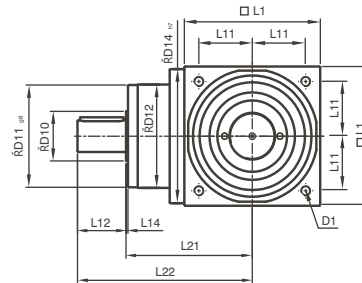
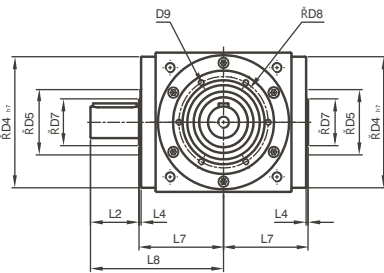
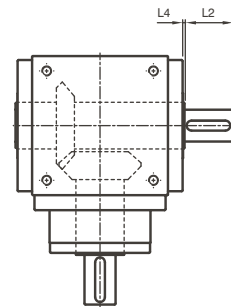

* The dimensions of ATB series are identical to AT series.

[unit: mm]

Dimension	AT065 L1/R1	AT075 L1/R1	AT090 L1/R1	AT110 L1/R1	AT140 L1/R1	AT170 L1/R1	AT210 L1/R1	AT240 L1/R1	AT280 L1/R1
D1	M4	M6	M6	M8	M10	M12	M16	M16	M16
D3 _{k6}	13	16	18	22	32	40	50	55	60
D4 _{h7}	63	73	88	108	135	165	205	235	275
D5	31	35	43	53	68	83	104	124	144
D6	M4	M5	M5	M8	M12	M16	M16	M16	M20
D7	21	22	28	33	47	55	75	85	110
D8	53	62	76	95	92	114	142	160	176
D9	4xM4xL7	4xM5xL8	4xM5xL8	6xM6xL10	6xM6xL10	6xM8xL12.5	6xM8xL12.5	6xM8xL12.5	6xM10xL15
D10	15.4	20.4	25.8	35.8	49.8	59.3	79.3	92.3	102.3
D11 _{g6}	62.9	72.9	87	107	103	127	158	178	198
D12	62	72	86	106	104	128	160	180	200
D13 _{k6}	13	16	18	22	32	40	50	55	60
D14 _{h7}	63	73	88	108	135	165	205	235	275
D16	M4	M5	M5	M8	M12	M16	M16	M16	M20
L1	65	75	90	110	140	170	210	240	280
L2	19.5	30	35	40	50	60	75	85	110
L3	13	14.5	15	15	15	15	20	25	25
L4	2	2	2	2	2	2	2	2	2
L5	16	25	28	32	45	50	70	80	100
L6	2	2.5	3.5	4	2.5	5	2.5	2.5	5
L7	47.5	54	62	72	87	102	127	147	167
L8	67	84	97	112	137	162	202	232	277
L9	4.5	4.8	4.8	7.2	10	12	12	12	15
L10	10	12.5	12.5	19	28	36	36	36	42
L11	27	30	36	44	55	67	85	95	110
L12	19.5	30	35	40	50	60	75	85	110
L13	13	15	15	15	15	15	20	25	25
L14	2	2	2	2	2	2	2	2	2
L15	16	25	28	32	45	50	70	80	100
L16	2	2.5	3.5	4	2.5	5	2.5	2.5	5
L17	6	8	8	8	10	10	10	10	10
L18	43	52.5	55	60	60	70	90	105	120
L19	4.5	4.8	4.8	7.2	10	12	12	12	15
L20	10	12.5	12.5	19	28	36	36	36	42
L21	75.5	90	100	115	130	155	195	225	260
L22	95	120	135	155	180	215	270	310	370
B1 _{h9}	5	5	6	6	10	12	14	16	18
B2 _{h9}	5	5	6	6	10	12	14	16	18
H1	15	18	20.5	24.5	35	43	53.5	59	64
H2	15	18	20.5	24.5	35	43	53.5	59	64

Dimensions (1-stage, Ratio $i=1\sim5$) AT-H / ATB-H Series

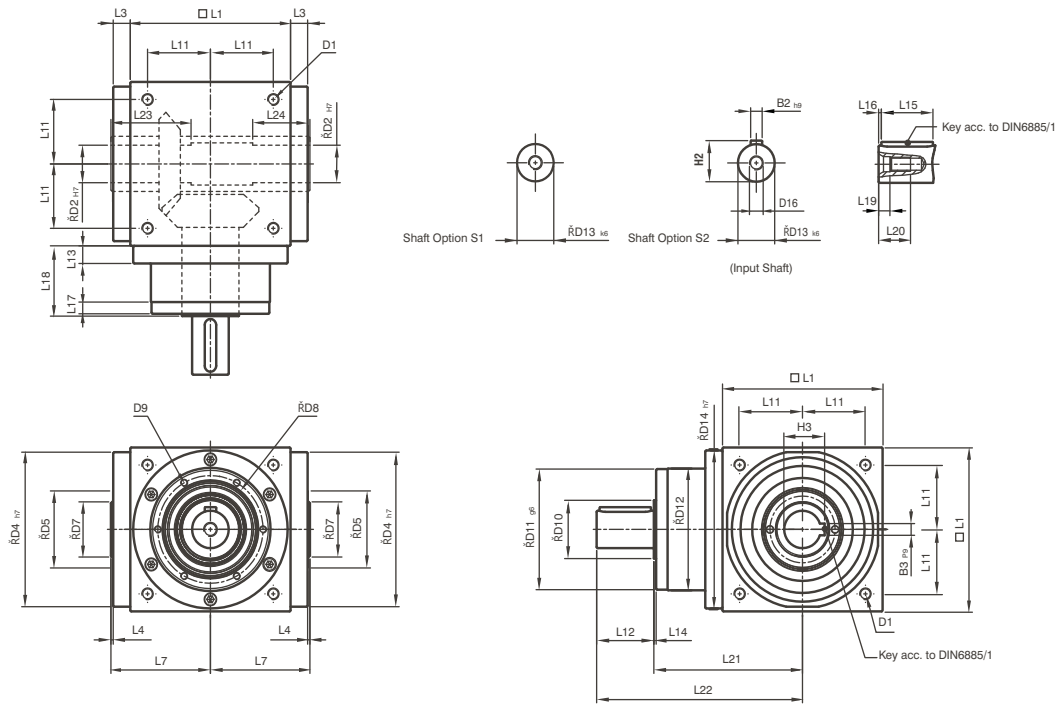

* The dimensions of ATB series are identical to AT series.

[unit: mm]

Dimension	AT065 H	AT075 H	AT090 H	AT110 H	AT140 H	AT170 H	AT210 H	AT240 H	AT280 H
D1	M4	M6	M6	M8	M10	M12	M16	M16	M16
D2 _{H7}	13	14	18	22	32	40	50	55	60
D4 _{H7}	63	73	88	108	135	165	205	235	275
D5	31	35	43	53	68	83	104	124	144
D7	21	22	28	33	47	55	75	85	110
D8	53	62	76	95	92	114	142	160	176
D9	4xM4xL7	4xM5xL8	4xM5xL8	6xM6xL10	6xM6xL10	6xM8xL12.5	6xM8xL12.5	6xM8xL12.5	6xM10xL15
D10	15.4	20.4	25.8	35.8	49.8	59.3	79.3	92.3	102.3
D11 _{G6}	62.9	72.9	87	107	103	127	158	178	198
D12	62	72	86	106	104	128	160	180	200
D13 _{K6}	13	16	18	22	32	40	50	55	60
D14 _{H7}	63	73	88	108	135	165	205	235	275
D16	M4	M5	M5	M8	M12	M16	M16	M16	M20
L1	65	75	90	110	140	170	210	240	280
L3	13	14.5	15	15	15	15	20	25	25
L4	2	2	2	2	2	2	2	2	2
L7	47.5	54	62	72	87	102	127	147	167
L11	27	30	36	44	55	67	85	95	110
L12	19.5	30	35	40	50	60	75	85	110
L13	13	15	15	15	15	15	20	25	25
L14	2	2	2	2	2	2	2	2	2
L15	16	25	28	32	45	50	70	80	100
L16	2	2.5	3.5	4	2.5	5	2.5	2.5	5
L17	6	8	8	8	10	10	10	10	10
L18	43	52.5	55	60	60	70	90	105	120
L19	4.5	4.8	4.8	7.2	10	12	12	12	15
L20	10	12.5	12.5	19	28	36	36	36	42
L21	75.5	90	100	115	130	155	195	225	260
L22	95	120	135	155	180	215	270	310	370
L23	40	47	52	53	70	80	95	115	115
L24	30	32	35	35	50	55	65	80	80
B2 _{H9}	5	5	6	6	10	12	14	16	18
B3 _{P9}	5	5	6	6	10	12	14	16	18
H2	15	18	20.5	24.5	35	43	53.5	59	64
H3	15.3	16.3	20.8	24.8	35.3	43.3	53.8	59.3	64.4

Dimensions (1-stage, Ratio $i=1\sim 5$)

AT-C / ATB-C Series

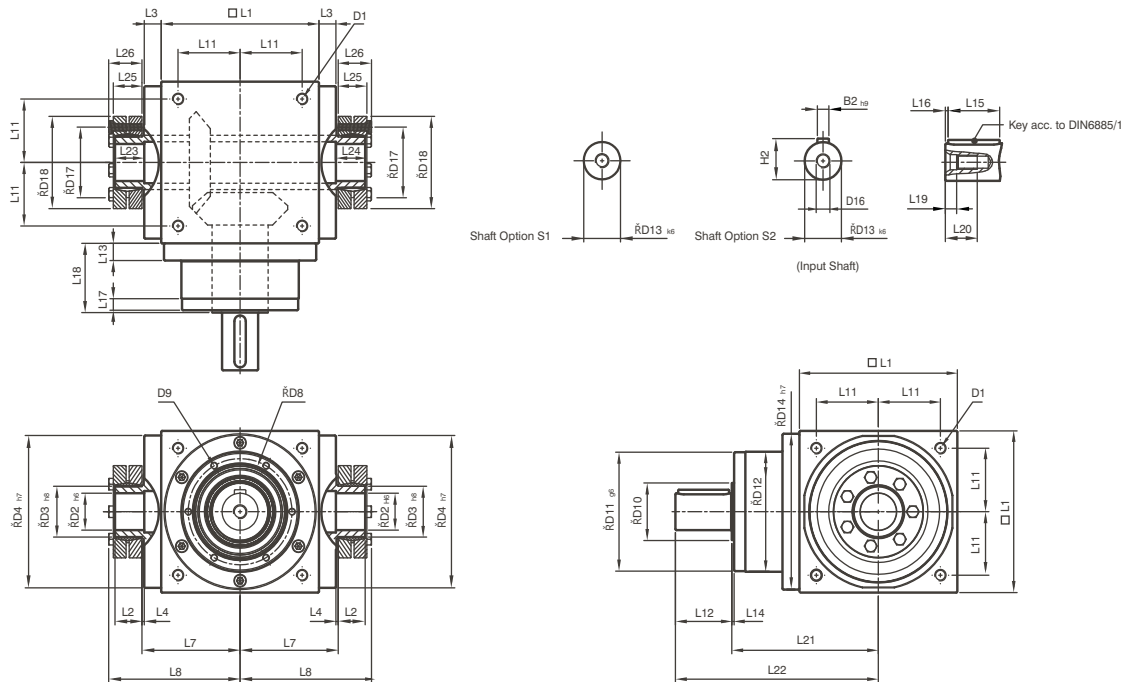

* The dimensions of ATB series are identical to AT series.

[unit: mm]

Dimension	AT065 C	AT075 C	AT090 C	AT110 C	AT140 C	AT170 C	AT210 C	AT240 C	AT280 C
D1	M4	M6	M6	M8	M10	M12	M16	M16	M16
D2 H6	13	14	18	22	32	40	50	55	60
D3 h8	16	16	22	25	44	50	62	68	75
D4 h7	63	73	88	108	135	165	205	235	275
D8	53	62	76	95	92	114	142	160	176
D9	4xM4xL7	4xM5xL8	4xM5xL8	6xM6xL10	6xM6xL10	6xM8xL12.5	6xM8xL12.5	6xM8xL12.5	6xM10xL15
D10	15.4	20.4	25.8	35.8	49.8	59.3	79.3	92.3	102.3
D11 g6	62.9	72.9	87	107	103	127	158	178	198
D12	62	72	86	106	104	128	160	180	200
D13 k6	13	16	18	22	32	40	50	55	60
D14 h7	63	73	88	108	135	165	205	235	275
D16	M4	M5	M5	M8	M12	M16	M16	M16	M20
D17	26	26	36	38	61	70	86	86	100
D18	41	41	50	50	80	90	110	115	138
L1	65	75	90	110	140	170	210	240	280
L2	14	14	18	18	24	26	29	29	30.5
L3	13	14.5	15	15	15	15	20	25	25
L4	2	2	2	2	2	2	2	2	2
L7	47.5	54	62	72	87	102	127	147	167
L8	66	72.5	85	95	116.5	133.5	161.5	181.5	205
L11	27	30	36	44	55	67	85	95	110
L12	19.5	30	35	40	50	60	75	85	110
L13	13	15	15	15	15	15	20	25	25
L14	2	2	2	2	2	2	2	2	2
L15	16	25	28	32	45	50	70	80	100
L16	2	2.5	3.5	4	2.5	5	2.5	2.5	5
L17	6	8	8	8	10	10	10	10	10
L18	43	52.5	55	60	60	70	90	105	120
L19	4.5	4.8	4.8	7.2	10	12	12	12	15
L20	10	12.5	12.5	19	28	36	36	36	42
L21	75.5	90	100	115	130	155	195	225	260
L22	95	120	135	155	180	215	270	310	370
L23	15	15	20	20	26	28	31	31	32.5
L24	15	15	20	20	26	28	31	31	32.5
L25	15	15	19.5	19.5	25.5	27.5	30.5	30.5	32.5
L26	18.5	18.5	23	23	29.5	31.5	34.5	34.5	38
B2 h9	5	5	6	6	10	12	14	16	18
H2	15	18	20.5	24.5	35	43	53.5	59	64

Dimensions (1-stage, Ratio $i=1$) AT-LM/RM | ATB-LM/RM Series

AT-LM

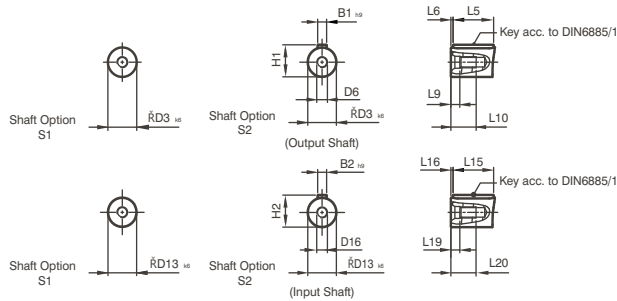
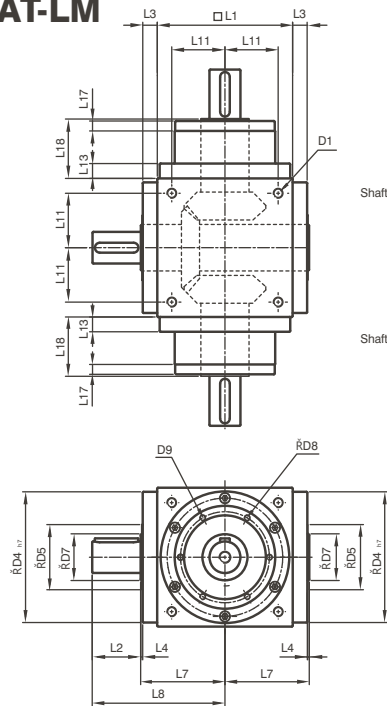

AT-RM

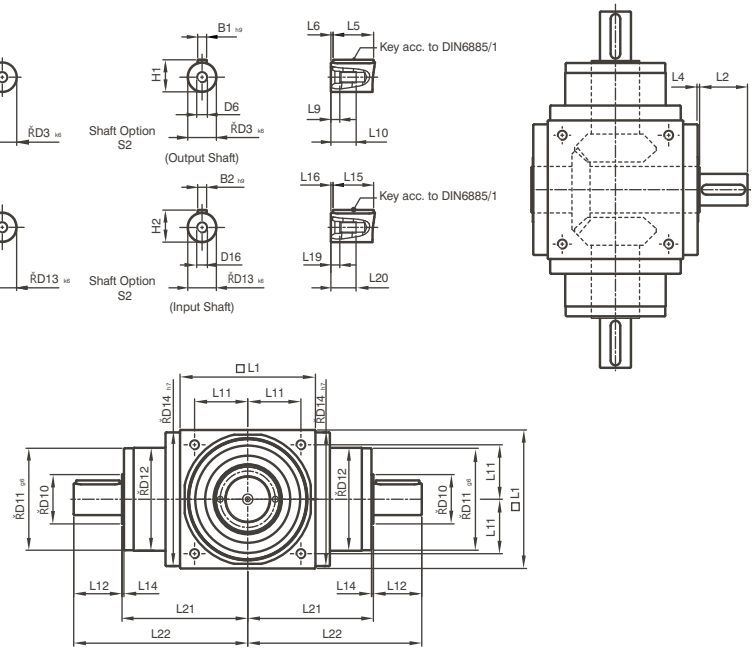

* The dimensions of ATB series are identical to AT series.

[unit: mm]

Dimension	AT065LM/RM	AT075LM/RM	AT090LM/RM	AT110LM/RM	AT140LM/RM	AT170LM/RM	AT210LM/RM	AT240LM/RM	AT280LM/RM
D1	M4	M6	M6	M8	M10	M12	M16	M16	M16
D3 k6	13	16	18	22	32	40	50	55	60
D4 h7	63	73	88	108	135	165	205	235	275
D5	31	35	43	53	68	83	104	124	144
D6	M4	M5	M5	M8	M12	M16	M16	M16	M20
D7	21	22	28	33	47	55	75	85	110
D8	53	62	76	95	92	114	142	160	176
D9	4xM4xL7	4xM5xL8	4xM5xL8	6xM6xL10	6xM6xL10	6xM8xL12.5	6xM8xL12.5	6xM8xL12.5	6xM10xL15
D10	15.4	20.4	25.8	35.8	49.8	59.3	79.3	92.3	102.3
D11 g6	62.9	72.9	87	107	103	127	158	178	198
D12	62	72	86	106	104	128	160	180	200
D13 k6	13	16	18	22	32	40	50	55	60
D14 h7	63	73	88	108	135	165	205	235	275
D16	M4	M5	M5	M8	M12	M16	M16	M16	M20
L1	65	75	90	110	140	170	210	240	280
L2	19.5	30	35	40	50	60	75	85	110
L3	13	14.5	15	15	15	15	20	25	25
L4	2	2	2	2	2	2	2	2	2
L5	16	25	28	32	45	50	70	80	100
L6	2	2.5	3.5	4	2.5	5	2.5	2.5	5
L7	47.5	54	62	72	87	102	127	147	167
L8	67	84	97	112	137	162	202	232	277
L9	4.5	4.8	4.8	7.2	10	12	12	12	15
L10	10	12.5	12.5	19	28	36	36	36	42
L11	27	30	36	44	55	67	85	95	110
L12	19.5	30	35	40	50	60	75	85	110
L13	13	15	15	15	15	15	20	25	25
L14	2	2	2	2	2	2	2	2	2
L15	16	25	28	32	45	50	70	80	100
L16	2	2.5	3.5	4	2.5	5	2.5	2.5	5
L17	6	8	8	8	10	10	10	10	10
L18	43	52.5	55	60	60	70	90	105	120
L19	4.5	4.8	4.8	7.2	10	12	12	12	15
L20	10	12.5	12.5	19	28	36	36	36	42
L21	75.5	90	100	115	130	155	195	225	260
L22	95	120	135	155	180	215	270	310	370
B1 h9	5	5	6	6	10	12	14	16	18
B2 h9	5	5	6	6	10	12	14	16	18
H1	15	18	20.5	24.5	35	43	53.5	59	64
H2	15	18	20.5	24.5	35	43	53.5	59	64

Dimensions (1-stage, Ratio i=1) AT-4M / ATB-4M Series

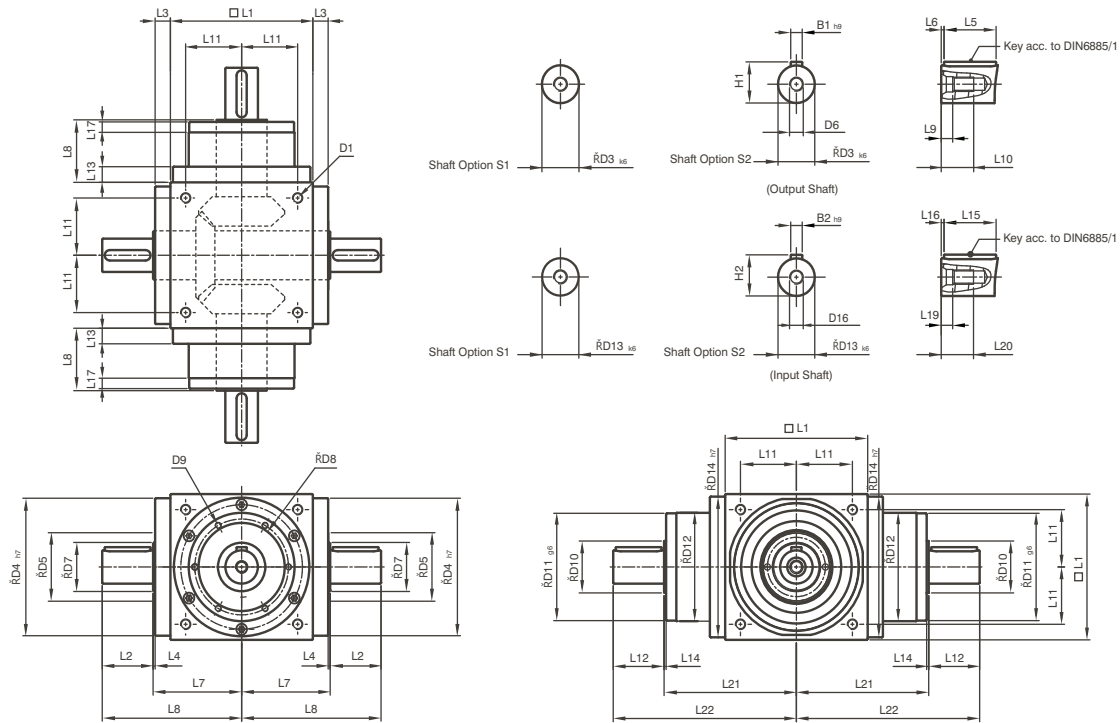

* The dimensions of ATB series are identical to AT series.

[unit: mm]

Dimension	AT065 4M	AT075 4M	AT090 4M	AT110 4M	AT140 4M	AT170 4M	AT210 4M	AT240 4M	AT280 4M
D1	M4	M6	M6	M8	M10	M12	M16	M16	M16
D3 k6	13	16	18	22	32	40	50	55	60
D4 h7	63	73	88	108	135	165	205	235	275
D5	31	35	43	53	68	83	104	124	144
D6	M4	M5	M5	M8	M12	M16	M16	M16	M20
D7	21	22	28	33	47	55	75	85	110
D8	53	62	76	95	92	114	142	160	176
D9	4xM4xL7	4xM5xL8	4xM5xL8	6xM6xL10	6xM6xL10	6xM8xL12.5	6xM8xL12.5	6xM8xL12.5	6xM10xL15
D10	15.4	20.4	25.8	35.8	49.8	59.3	79.3	92.3	102.3
D11 g6	62.9	72.9	87	107	103	127	158	178	198
D12	62	72	86	106	104	128	160	180	200
D13 k6	13	16	18	22	32	40	50	55	60
D14 h7	63	73	88	108	135	165	205	235	275
D16	M4	M5	M5	M8	M12	M16	M16	M16	M20
L1	65	75	90	110	140	170	210	240	280
L2	19.5	30	35	40	50	60	75	85	110
L3	13	14.5	15	15	15	15	20	25	25
L4	2	2	2	2	2	2	2	2	2
L5	16	25	28	32	45	50	70	80	100
L6	2	2.5	3.5	4	2.5	5	2.5	2.5	5
L7	47.5	54	62	72	87	102	127	147	167
L8	67	84	97	112	137	162	202	232	277
L9	4.5	4.8	4.8	7.2	10	12	12	12	15
L10	10	12.5	12.5	19	28	36	36	36	42
L11	27	30	36	44	55	67	85	95	110
L12	19.5	30	35	40	50	60	75	85	110
L13	13	15	15	15	15	15	20	25	25
L14	2	2	2	2	2	2	2	2	2
L15	16	25	28	32	45	50	70	80	100
L16	2	2.5	3.5	4	2.5	5	2.5	2.5	5
L17	6	8	8	8	10	10	10	10	10
L18	43	52.5	55	60	60	70	90	105	120
L19	4.5	4.8	4.8	7.2	10	12	12	12	15
L20	10	12.5	12.5	19	28	36	36	36	42
L21	75.5	90	100	115	130	155	195	225	260
L22	95	120	135	155	180	215	270	310	370
B1 h9	5	5	6	6	10	12	14	16	18
B2 h9	5	5	6	6	10	12	14	16	18
H1	15	18	20.5	24.5	35	43	53.5	59	64
H2	15	18	20.5	24.5	35	43	53.5	59	64

Specifications

AT / ATB Flange Type Series

Gearbox Performance (The performance and specification of ATB series are identical to AT series.)

Model No.	Stage	Ratio ^A	AT065 FL	AT075 FL	AT090 FL	AT110 FL	AT140 FL	AT170 FL	AT210 FL	AT240 FL	AT280 FL		
			AT065 FL1	AT075 FL1	AT090 FL1	AT110 FL1	AT140 FL1	AT170 FL1	AT210 FL1	AT240 FL1	AT280 FL1		
			AT065 FH	AT075 FH	AT090 FH	AT110 FH	AT140 FH	AT170 FH	AT210 FH	AT240 FH	AT280 FH		
			AT065 FC	AT075 FC	AT090 FC	AT110 FC	AT140 FC	AT170 FC	AT210 FC	AT240 FC	AT280 FC		
			AT065 FR1	AT075 FR1	AT090 FR1	AT110 FR1	AT140 FR1	AT170 FR1	AT210 FR1	AT240 FR1	AT280 FR1		
Nominal Output Torque T_{2N}	1	1	25	45	78	150	360	585	1,300	2,150	3,200		
		1.5	25	45	78	150	360	585	1,300	2,150	3,200		
		2	24	42	68	150	330	544	1,220	2,010	3,050		
		3	18	33	54	120	270	450	1,020	1,650	2,850		
		4	13	28	48	100	224	376	860	1,410	2,300		
		5	12	25	40	85	196	320	740	1,210	2,000		
		2	7	12	12	33	91	91	91	195	358	358	
			10	24	28	68	150	208	208	430	846	846	
			15	18	33	54	120	270	312	645	1,269	1,269	
			20	13	28	48	100	224	376	860	1,410	1,692	
	25		12	25	40	85	196	320	740	1,210	2,000		
	35		12	25	40	85	196	320	740	1,210	1,790		
	50		12	25	40	85	196	320	740	1,210	1,465		
	3	75	-	-	-	120	210	312	585	1,269	1,269		
		100	-	-	-	100	224	376	780	1,410	1,692		
		125	-	-	-	85	196	320	740	1,210	2,000		
		150	-	-	-	120	135	312	390	975	975		
		200	-	-	-	100	180	376	520	1,300	1,300		
		250	-	-	-	85	196	320	650	1,210	1,625		
		350	-	-	-	85	196	320	740	1,210	1,790		
		500	-	-	-	85	196	320	740	1,210	1,465		
	Max. Acceleration Torque T_{2B}	Nm	1,2,3	1~500	1.5 times of Nominal Output Torque								
	Max. Acceleration Input Speed n_{1B}	rpm	1	1~5	7,500	6,500	5,500	4,500	3,500	3,000	2,200	2,000	1,700
			2	7~50	8,000	8,000	6,000	6,000	6,000	6,000	4,800	3,600	3,600
			3	75~500	-	-	-	8,000	8,000	6,000	6,000	6,000	6,000
	Standard Backlash ^B	arcmin	1	1~5	≤6	≤6	≤6	≤6	≤6	≤6	≤6	≤6	≤6
			2	7~50	≤8	≤8	≤8	≤8	≤8	≤8	≤8	≤8	≤8
			3	75~500	-	-	-	≤10	≤10	≤10	≤10	≤10	≤10
Max. Radial Load F_{2aB}^C Output d2	N	1,2,3	1~500	900	1,100	1,700	2,700	4,800	6,600	11,500	16,000	18,000	
Max. Axial Load F_{2aB}^C Output d2	N	1,2,3	1~500	450	550	850	1,350	2,400	3,300	5,750	8,500	9,000	
Efficiency η	%	1	1~5	98%									
		2,3	7~500	94%									
Operating Temp	°C	1,2,3	1~500	-10°C ~ 90°C									
Lubrication				Synthetic lubrication oils									
Noise Level ^D	dB (A)	1,2,3	1~500	≤71	≤72	≤76	≤77	≤78	≤79	≤81	≤83	≤84	

Specifications

AT / ATB Flange Type Series

Gearbox Inertia (The performance and specification of ATB series are identical to AT series.)

Model No.	Stage	Ratio ^A	AT065 FL	AT075 FL	AT090 FL	AT110 FL	AT140 FL	AT170 FL	AT210 FL	AT240 FL	AT280 FL
			AT065 FL1	AT075 FL1	AT090 FL1	AT110 FL1	AT140 FL1	AT170 FL1	AT210 FL1	AT240 FL1	AT280 FL1
			AT065 FH	AT075 FH	AT090 FH	AT110 FH	AT140 FH	AT170 FH	AT210 FH	AT240 FH	AT280 FH
			AT065 FC	AT075 FC	AT090 FC	AT110 FC	AT140 FC	AT170 FC	AT210 FC	AT240 FC	AT280 FC
			AT065 FR1	AT075 FR1	AT090 FR1	AT110 FR1	AT140 FR1	AT170 FR1	AT210 FR1	AT240 FR1	AT280 FR1
Mass Moments of Inertia J _i	1	1	0.51	1.30	3.14	7.62	23.54	59.09	195.96	365.38	787.63
		1.5	0.46	1.15	2.80	6.65	19.34	49.38	156.02	279.62	584.28
		2	0.44	1.10	2.68	6.23	17.72	45.44	140.80	245.78	500.26
		3	0.43	1.09	2.64	6.08	17.16	44.11	135.51	233.75	471.56
		4	0.43	1.08	2.63	6.05	17.03	43.79	134.14	230.77	464.76
		5	0.43	1.08	2.63	6.04	16.99	43.69	133.71	229.71	462.08
	2	7	0.15	0.15	0.50	2.79	2.79	2.79	9.91	29.26	29.26
		10	0.15	0.15	0.50	2.80	2.80	2.80	9.96	29.43	29.43
		15	0.15	0.15	0.50	2.80	2.80	2.80	9.96	29.43	29.43
		20	0.15	0.15	0.50	2.80	2.80	2.80	9.96	29.43	29.43
		25	0.15	0.15	0.50	2.80	2.80	2.80	9.96	29.43	29.43
		35	0.15	0.15	0.50	2.79	2.79	2.79	9.91	29.26	29.26
	3	50	0.15	0.15	0.50	2.79	2.79	2.79	9.89	29.20	29.20
		75	-	-	-	0.15	0.15	0.50	0.50	2.80	2.80
		100	-	-	-	0.15	0.15	0.50	0.50	2.80	2.80
		125	-	-	-	0.15	0.15	0.50	0.50	2.80	2.80
		150	-	-	-	0.15	0.15	0.50	0.50	2.79	2.79
		200	-	-	-	0.15	0.15	0.50	0.50	2.79	2.79
		250	-	-	-	0.15	0.15	0.50	0.50	2.79	2.79
		350	-	-	-	0.15	0.15	0.50	0.50	2.79	2.79
	500	-	-	-	0.15	0.15	0.50	0.50	2.79	2.79	

Weight

Model No.	Stage	Ratio ^A	AT065	AT075	AT090	AT110	AT140	AT170	AT210	AT240	AT280
FL Series	1	1~5	2.8	4.4	7.1	12.1	20.9	36.1	69.4	101.2	158.3
	2	7~50	3.2	4.8	8.1	14.3	24.2	38.5	74.1	112.4	171.0
	3	75~500	-	-	-	13.9	23.7	38.8	73.4	110.2	168.7
FL1 Series	1	1~5	2.7	4.3	7.1	11.9	20.3	35.5	68.3	99.6	156.0
	2	7~50	3.2	4.8	8.0	14.2	23.9	37.9	73.0	110.8	168.6
	3	75~500	-	-	-	13.8	23.4	38.2	72.3	108.6	166.4
FH Series	1	1~5	2.6	4.1	6.7	11.4	18.9	32.9	63.2	92.5	146.0
	2	7~50	3.1	4.6	7.7	13.6	22.4	35.3	67.9	103.7	158.7
	3	75~500	-	-	-	13.3	21.9	35.6	67.2	101.5	156.5
FC Series	1	1~5	2.9	4.4	7.2	11.8	20.4	35.0	66.5	96.0	151.7
	2	7~50	3.3	4.9	8.2	14.1	24.1	37.4	71.2	107.2	164.4
	3	75~500	-	-	-	13.7	23.5	37.5	70.5	105.0	162.2
FR1 Series	1	1~5	2.7	4.3	7.1	11.9	20.3	35.5	68.3	99.6	156.0
	2	7~50	3.2	4.8	8.0	14.2	23.9	37.9	73.0	110.8	168.6
	3	75~500	-	-	-	13.8	23.4	38.2	72.3	108.6	166.4

A. Ratio ($i = N_n / N_{out}$).

B. Backlash is measured at 2% Nominal Torque T_{2N} .

C. Apply to the output shaft center at n_{1B} .

D. The dB values are measured by gearbox with ratio 5 (1-stage) or ratio 50 (2-stage) or ratio 500 (3-stage), no loading at 1,500 RPM or at the respective Nominal Input Speed by bigger model size.

By lower ratio and / or higher RPM, the noise level could be 3 to 5 dB higher.

E. One year warranty.

Dimensions (1-stage, Ratio $i=1\sim5$) AT-FL / ATB-FL Series

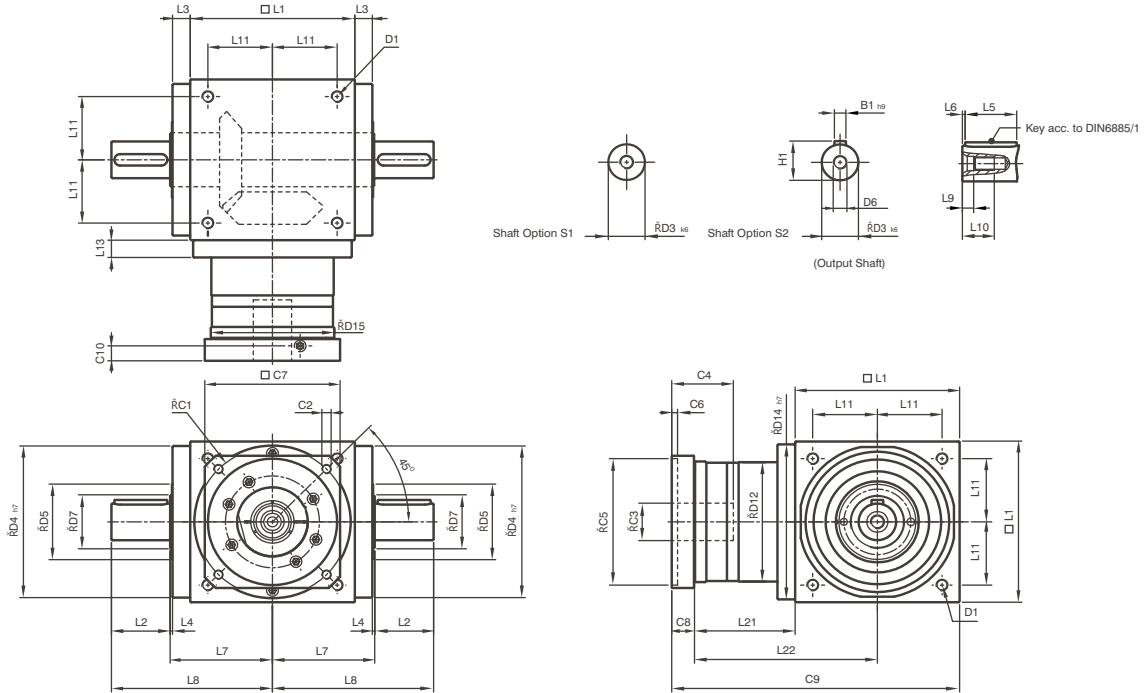

* The dimensions of ATB series are identical to AT series.

[unit: mm]

Dimension	AT065 FL	AT075 FL	AT090 FL	AT110 FL	AT140 FL	AT170 FL	AT210 FL	AT240 FL	AT280 FL
D1	M4	M6	M6	M8	M10	M12	M16	M16	M16
D3 k6	13	16	18	22	32	40	50	55	60
D4 h7	63	73	88	108	135	165	205	235	275
D5	31	35	43	53	68	83	104	124	144
D6	M4	M5	M5	M8	M12	M16	M16	M16	M20
D7	21	22	28	33	47	55	75	85	110
D12	62	72	86	106	104	128	160	180	200
D14 h7	63	73	88	108	135	165	205	235	275
D15	62.9	72.9	87	107	105	130	158	178	198
L1	65	75	90	110	140	170	210	240	280
L2	19.5	30	35	40	50	60	75	85	110
L3	13	14.5	15	15	15	15	20	25	25
L4	2	2	2	2	2	2	2	2	2
L5	16	25	28	32	45	50	70	80	100
L6	2	2.5	3.5	4	2.5	5	2.5	2.5	5
L7	47.5	54	62	72	87	102	127	147	167
L8	67	84	97	112	137	162	202	232	277
L9	4.5	4.8	4.8	7.2	10	12	12	12	15
L10	10	12.5	12.5	19	28	36	36	36	42
L11	27	30	36	44	55	67	85	95	110
L13	13	15	15	15	15	15	20	25	25
L21	49	60.5	63	69.5	85.5	95	130	144.5	135
L22	81.5	98	108	124.5	155.5	180	235	264.5	275
C1 ¹	46	70	100	100	130	165	215	215	235
C2 ¹	M4	M5	M6	M6	M8	M10	M12	M12	M12
C3 ¹	≤11 / ≤12 ²	≤14 / ≤15.875 / ≤16 ²	≤19	≤24	≤32	≤38	≤42	≤48	≤55
C4 ¹	30	34	40	40	50	60	85	85	116
C5 ¹	30	50	80	80	110	130	180	180	200
C6 ¹	3.5	8	4	4	5	6	6	6	6
C7 ¹	42	60	90	90	115	142	190	190	220
C8 ¹	19.5	19	17	17	19.5	22.5	29	29	63
C9 ¹	133.5	154.5	170	196.5	245	287.5	369	413.5	478
C10 ¹	13.25	13.5	10.75	10.75	13	15	20.75	20.75	53.5
B1 h9	5	5	6	6	10	12	14	16	18
H1	15	18	20.5	24.5	35	43	53.5	59	64

1. C1~C10 are motor specific dimensions (metric std shown).

2. AT065 FLM1 offers C3 ≤12 option; AT075 FLM1 offers C3 ≤16 option; AT075 FLM2 offers C3 ≤15.875 option.

Dimensions (2-stage, Ratio $i=7\sim 50$)

AT-FL / ATB-FL Series

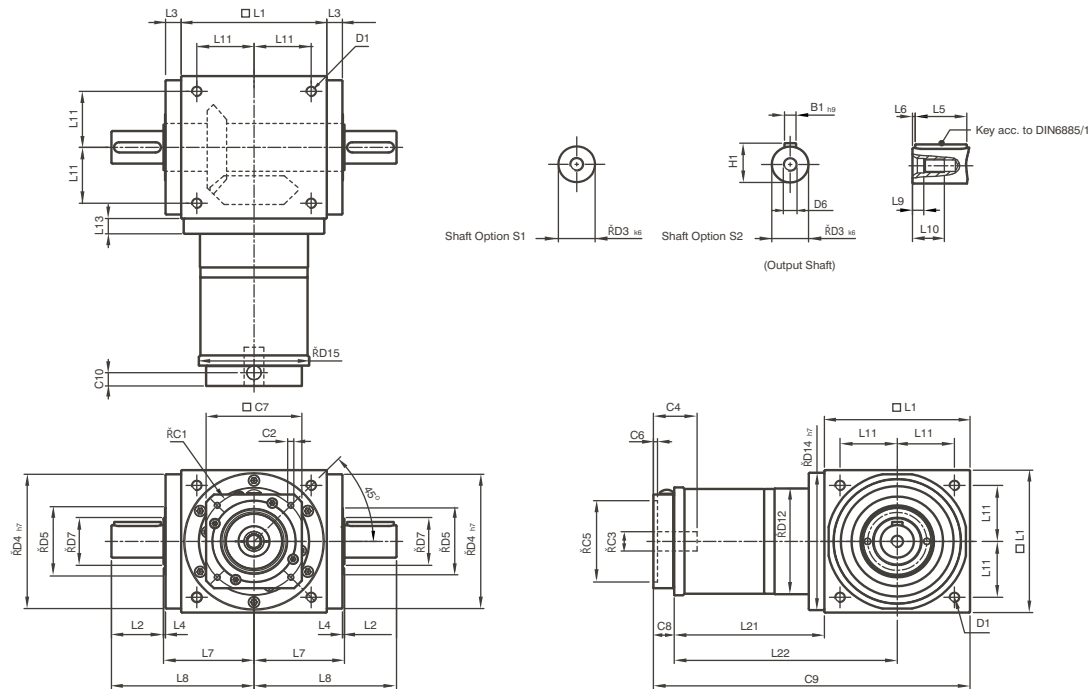

* The dimensions of ATB series are identical to AT series.

[unit: mm]

Dimension	AT065 FL	AT075 FL	AT090 FL	AT110 FL	AT140 FL	AT170 FL	AT210 FL	AT240 FL	AT280 FL
D1	M4	M6	M6	M8	M10	M12	M16	M16	M16
D3 _{k6}	13	16	18	22	32	40	50	55	60
D4 _{h7}	63	73	88	108	135	165	205	235	275
D5	31	35	43	53	68	83	104	124	144
D6	M4	M5	M5	M8	M12	M16	M16	M16	M20
D7	21	22	28	33	47	55	75	85	110
D12	62	72	86	106	104	128	160	180	200
D14 _{h7}	63	73	88	108	135	165	205	235	275
D15	62.9	72.9	87	107	106	130	158	178	198
L1	65	75	90	110	140	170	210	240	280
L2	19.5	30	35	40	50	60	75	85	110
L3	13	14.5	15	15	15	15	20	25	25
L4	2	2	2	2	2	2	2	2	2
L5	16	25	28	32	45	50	70	80	100
L6	2	2.5	3.5	4	2.5	5	2.5	2.5	5
L7	47.5	54	62	72	87	102	127	147	167
L8	67	84	97	112	137	162	202	232	277
L9	4.5	4.8	4.8	7.2	10	12	12	12	15
L10	10	12.5	12.5	19	28	36	36	36	42
L11	27	30	36	44	55	67	85	95	110
L13	13	15	15	15	15	15	20	25	25
L21	75	84.5	99	122	144.5	157.5	206.5	239	248
L22	107.5	122	144	177	214.5	242.5	311.5	359	388
C1 ³	46	46	70	100	100	100	130	165	165
C2 ³	M4	M4	M5	M6	M6	M6	M8	M10	M10
C3 ³	≤12	≤12	≤16	≤24	≤24	≤24	≤32	≤38	≤38
C4 ³	30	30	34	40	40	40	50	60	60
C5 ³	30	30	50	80	80	80	110	130	130
C6 ³	3.5	3.5	8	4	4	4	5	6	6
C7 ³	42	42	60	92	92	92	115	142	142
C8 ³	21.5	21.5	21.5	20	20	20	24	31	31
C9 ³	161.5	181	210.5	252	304.5	347.5	440.5	510	559
C10 ³	14.5	14.5	15.5	13	13	13	16	21	21
B1 _{h9}	5	5	6	6	10	12	14	16	18
H1	15	18	20.5	24.5	35	43	53.5	59	64

3. C1-C10 are motor specific dimensions (metric std shown).

Dimensions (3-stage, Ratio $i=75\sim 500$) AT-FL / ATB-FL Series

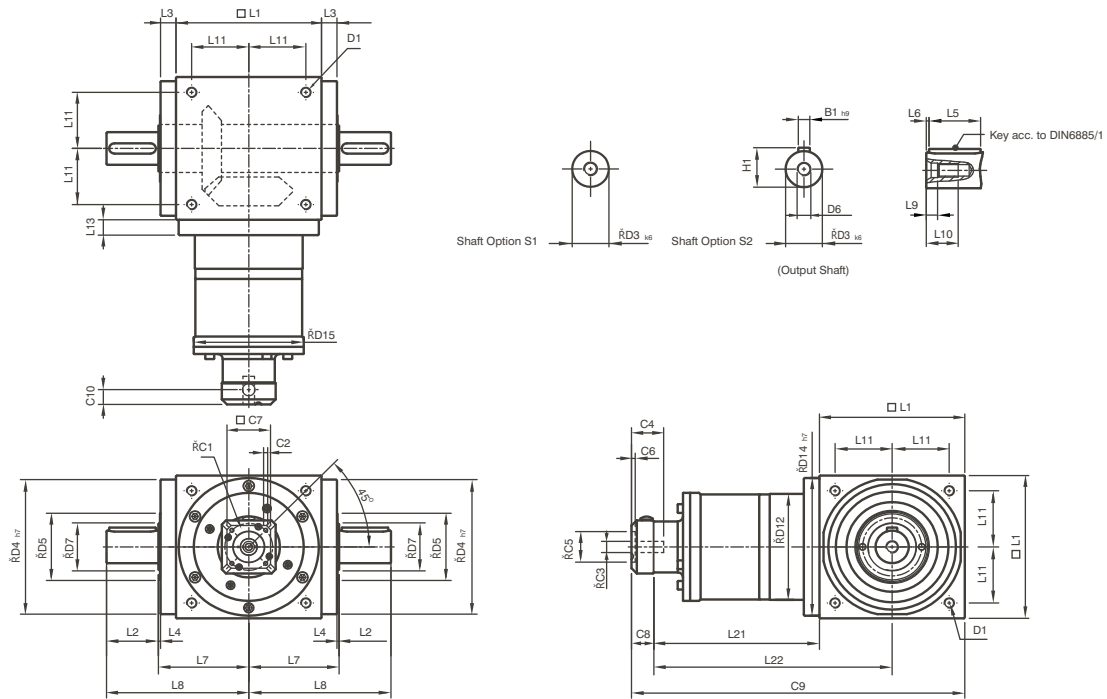

* The dimensions of ATB series are identical to AT series.

[unit: mm]

Dimension	AT110 FL	AT140 FL	AT170 FL	AT210 FL	AT240 FL	AT280 FL
D1	M8	M10	M12	M16	M16	M16
D3 k6	22	32	40	50	55	60
D4 h7	108	135	165	205	235	275
D5	53	68	83	104	124	144
D6	M8	M12	M16	M16	M16	M20
D7	33	47	55	75	85	110
D12	106	104	128	160	180	200
D14 h7	108	135	165	205	235	275
D15	107	106	130	158	178	198
L1	110	140	170	210	240	280
L2	40	50	60	75	85	110
L3	15	15	15	20	25	25
L4	2	2	2	2	2	2
L5	32	45	50	70	80	100
L6	4	2.5	5	2.5	2.5	5
L7	72	87	102	127	147	167
L8	112	137	162	202	232	277
L9	7.2	10	12	12	12	15
L10	19	28	36	36	36	42
L11	44	55	67	85	95	110
L13	15	15	15	20	25	25
L21	136.5	159.5	183.5	226	269	278
L22	191.5	229.5	268.5	331	389	418
C1 ⁴	46	46	70	70	100	100
C2 ⁴	M4	M4	M5	M5	M6	M6
C3 ⁴	≤12	≤12	≤16	≤16	≤24	≤24
C4 ⁴	30	30	34	34	40	40
C5 ⁴	30	30	50	50	80	80
C6 ⁴	3.5	3.5	8	8	4	4
C7 ⁴	42	42	60	60	92	92
C8 ⁴	21.5	21.5	21.5	21.5	20	20
C9 ⁴	268	321	375	457.5	529	578
C10 ⁴	14.5	14.5	15.5	15.5	13	13
B1 h9	6	10	12	14	16	18
H1	24.5	35	43	53.5	59	64

4. C1~C10 are motor specific dimensions (metric std shown).

Dimensions (1-stage, Ratio $i = 1 \sim 5$)

AT-FL1/FR1 | ATB-FL1/FR1 Series

AT-FL1 / ATB-FL1

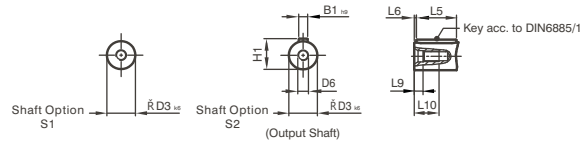
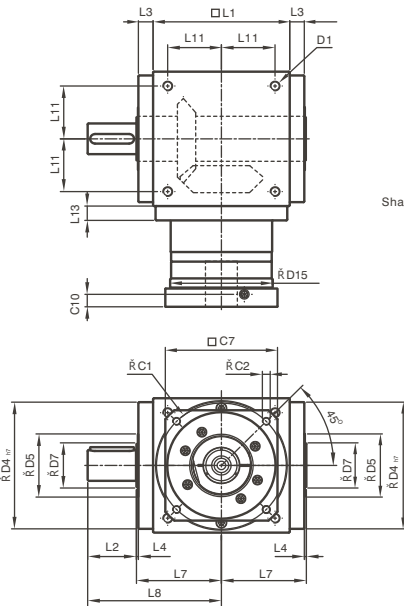

AT-FR1 / ATB-FR1

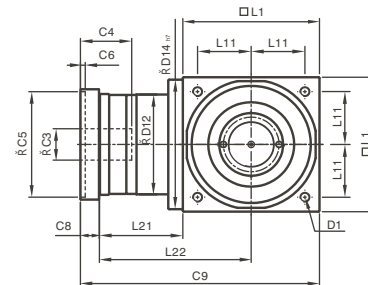
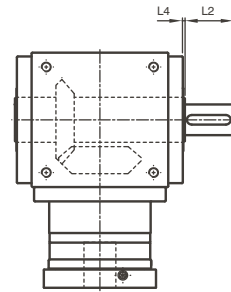

* The dimensions of ATB series are identical to AT series.

[unit: mm]

Dimension	AT065 FL1/FR1	AT075 FL1/FR1	AT090 FL1/FR1	AT110 FL1/FR1	AT140 FL1/FR1	AT170 FL1/FR1	AT210 FL1/FR1	AT240 FL1/FR1	AT280 FL1/FR1
D1	M4	M6	M6	M8	M10	M12	M16	M16	M16
D3 _{k6}	13	16	18	22	32	40	50	55	60
D4 _{h7}	63	73	88	108	135	165	205	235	275
D5	31	35	43	53	68	83	104	124	144
D6	M4	M5	M5	M8	M12	M16	M16	M16	M20
D7	21	22	28	33	47	55	75	85	110
D12	62	72	86	106	104	128	160	180	200
D14 _{h7}	63	73	88	108	135	165	205	235	275
D15	62.9	72.9	87	107	105	130	158	178	198
L1	65	75	90	110	140	170	210	240	280
L2	19.5	30	35	40	50	60	75	85	110
L3	13	14.5	15	15	15	15	20	25	25
L4	2	2	2	2	2	2	2	2	2
L5	16	25	28	32	45	50	70	80	100
L6	2	2.5	3.5	4	2.5	5	2.5	2.5	5
L7	47.5	54	62	72	87	102	127	147	167
L8	67	84	97	112	137	162	202	232	277
L9	4.5	4.8	4.8	7.2	10	12	12	12	15
L10	10	12.5	12.5	19	28	36	36	36	42
L11	27	30	36	44	55	67	85	95	110
L13	13	15	15	15	15	15	20	25	25
L21	49	60.5	63	69.5	85.5	95	130	144.5	135
L22	81.5	98	108	124.5	155.5	180	235	264.5	275
C1 ⁵	46	70	100	100	130	165	215	215	235
C2 ⁵	M4	M5	M6	M6	M8	M10	M12	M12	M12
C3 ⁵	≤11 / ≤12 ⁶	≤14 / ≤15.875 / ≤16 ⁶	≤19	≤24	≤32	≤38	≤42	≤48	≤55
C4 ⁵	30	34	40	40	50	60	85	85	116
C5 ⁵	30	50	80	80	110	130	180	180	200
C6 ⁵	3.5	8	4	4	5	6	6	6	6
C7 ⁵	42	60	90	90	115	142	190	190	220
C8 ⁵	19.5	19	17	17	19.5	22.5	29	29	63
C9 ⁵	133.5	154.5	170	196	245	287.5	369	413.5	478
C10 ⁵	13.25	13.5	10.75	510	13	15	20.75	20.75	53.5
B1 _{h9}	5	5	6	75	10	12	14	16	18
H1	15	18	20.5	6	35	43	53.5	59	64

5. C1~C10 are motor specific dimensions (metric std shown).

6. AT065 FL1/FR1M1 offers C3 ≤12 option; AT075 FL1/FR1M1 offers C3 ≤16 option; AT075 FL1/FR1M2 offers C3 ≤15.875 option.

Dimensions (2-stage, Ratio $i=7\sim 50$) AT-FL1/FR1 | ATB-FL1/FR1 Series

AT-FL1 / ATB-FL1

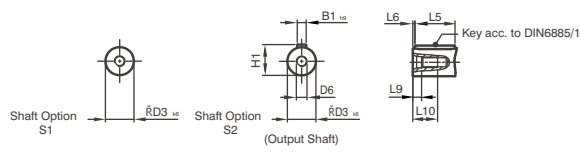
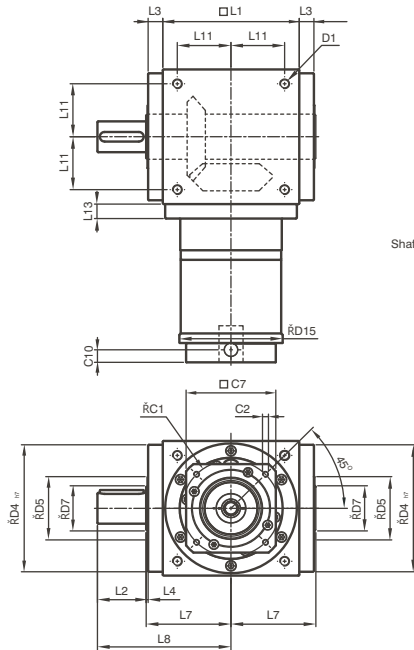

AT-FR1 / ATB-FR1

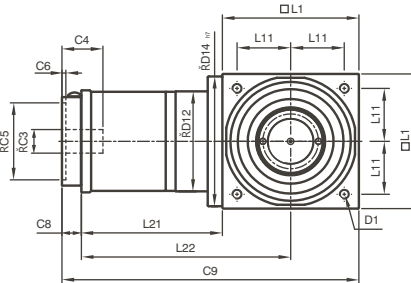
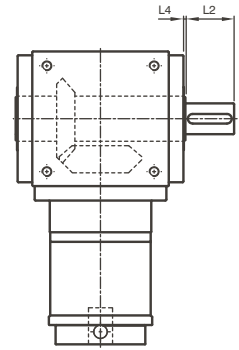

* The dimensions of ATB series are identical to AT series.

[unit: mm]

Dimension	AT065 FL1/FR1	AT075 FL1/FR1	AT090 FL1/FR1	AT110 FL1/FR1	AT140 FL1/FR1	AT170 FL1/FR1	AT210 FL1/FR1	AT240 FL1/FR1	AT280 FL1/FR1
D1	M4	M6	M6	M8	M10	M12	M16	M16	M16
D3 k6	13	16	18	22	32	40	50	55	60
D4 h7	63	73	88	108	135	165	205	235	275
D5	31	35	43	53	68	83	104	124	144
D6	M4	M5	M5	M8	M12	M16	M16	M16	M20
D7	21	22	28	33	47	55	75	85	110
D12	62	72	86	106	104	128	160	180	200
D14 h7	63	73	88	108	135	165	205	235	275
D15	62.9	72.9	87	107	106	130	158	178	198
L1	65	75	90	110	140	170	210	240	280
L2	19.5	30	35	40	50	60	75	85	110
L3	13	14.5	15	15	15	15	20	25	25
L4	2	2	2	2	2	2	2	2	2
L5	16	25	28	32	45	50	70	80	100
L6	2	2.5	3.5	4	2.5	5	2.5	2.5	5
L7	47.5	54	62	72	87	102	127	147	167
L8	67	84	97	112	137	162	202	232	277
L9	4.5	4.8	4.8	7.2	10	12	12	12	15
L10	10	12.5	12.5	19	28	36	36	36	42
L11	27	30	36	44	55	67	85	95	110
L13	13	15	15	15	15	15	20	25	25
L21	75	84.5	99	122	144.5	157.5	206.5	239	248
L22	107.5	122	144	177	214.5	242.5	311.5	359	388
C1 ⁷	46	46	70	100	100	100	130	165	165
C2 ⁷	M4	M4	M5	M6	M6	M6	M8	M10	M10
C3 ⁷	≤12	≤12	≤16	≤24	≤24	≤24	≤32	≤38	≤38
C4 ⁷	30	30	34	40	40	40	50	60	60
C5 ⁷	30	30	50	80	80	80	110	130	130
C6 ⁷	3.5	3.5	8	4	4	4	5	6	6
C7 ⁷	42	42	60	92	92	92	115	142	142
C8 ⁷	21.5	21.5	21.5	20	20	20	24	31	31
C9 ⁷	161.5	181	210.5	252	304.5	347.5	440.5	510	559
C10 ⁷	14.55	14.5	15.5	13	13	13	16	21	21
B1 h9	5	5	6	6	10	12	14	16	18
H1	15	18	20.5	24.5	35	43	53.5	59	64

7. C1~C10 are motor specific dimensions (metric std shown).

Dimensions (3-stage, Ratio $i=75\sim 500$)

AT-FL1/FR1 | ATB-FL1/FR1 Series

AT-FL1 / ATB-FL1

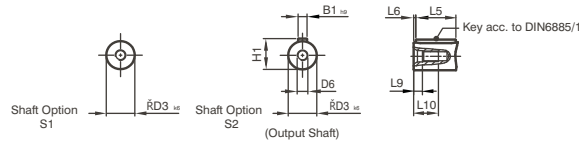
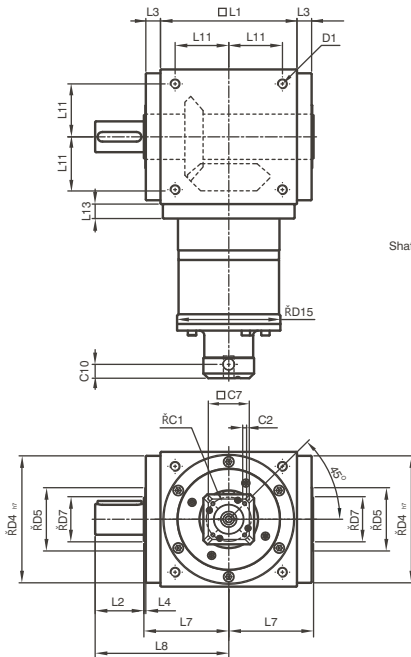

AT-FR1 / ATB-FR1

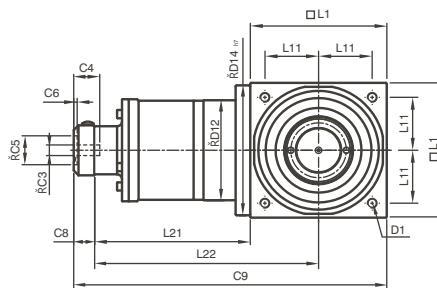
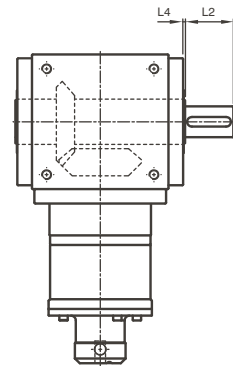

* The dimensions of ATB series are identical to AT series.

[unit: mm]

Dimension	AT110 FL1/FR1	AT140 FL1/FR1	AT170 FL1/FR1	AT210 FL1/FR1	AT240 FL1/FR1	AT280 FL1/FR1
D1	M8	M10	M12	M16	M16	M16
D3 k6	22	32	40	50	55	60
D4 h7	108	135	165	205	235	275
D5	53	68	83	104	124	144
D6	M8	M12	M16	M16	M16	M20
D7	33	47	55	75	85	110
D12	106	104	128	160	180	200
D14 h7	108	135	165	205	235	275
D15	107	106	130	158	178	198
L1	110	140	170	210	240	280
L2	40	50	60	75	85	110
L3	15	15	15	20	25	25
L4	2	2	2	2	2	2
L5	32	45	50	70	80	100
L6	4	2.5	5	2.5	2.5	5
L7	72	87	102	127	147	167
L8	112	137	162	202	232	277
L9	7.2	10	12	12	12	15
L10	19	28	36	36	36	42
L11	44	55	67	85	95	110
L13	15	15	15	20	25	25
L21	136.5	159.5	183.5	226	269	278
L22	191.5	229.5	268.5	331	389	418
C1 ⁸	46	46	70	70	100	100
C2 ⁸	M4	M4	M5	M5	M6	M6
C3 ⁸	≤12	≤12	≤16	≤16	≤24	≤24
C4 ⁸	30	30	34	34	40	40
C5 ⁸	30	30	50	50	80	80
C6 ⁸	3.5	3.5	8	8	4	4
C7 ⁸	42	42	60	60	92	92
C8 ⁸	21.5	21.5	21.5	21.5	20	20
C9 ⁸	268	321	375	457.5	529	578
C10 ⁸	14.5	14.5	15.5	15.5	13	13
B1 h9	6	10	12	14	16	18
H1	24.5	35	43	53.5	59	64

8. C1~C10 are motor specific dimensions (metric std shown).

Dimensions (1-stage, Ratio i=1~5)

AT-FH / ATB-FH Series

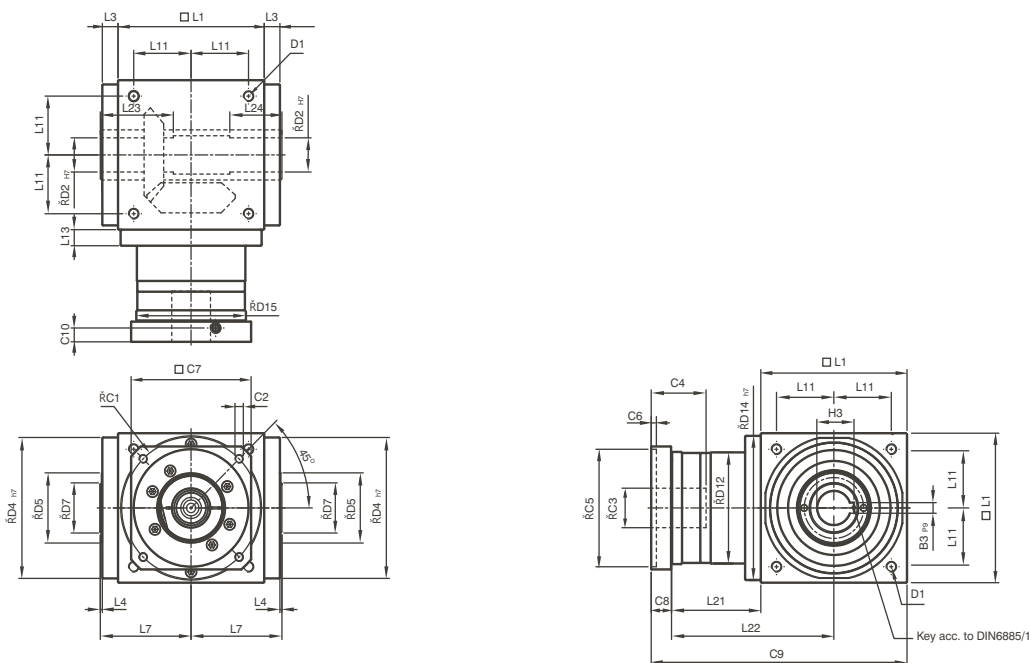

* The dimensions of ATB series are identical to AT series.

[unit: mm]

Dimension	AT065FH	AT075FH	AT090FH	AT110FH	AT140FH	AT170FH	AT210FH	AT240FH	AT280FH
D1	M4	M6	M6	M8	M10	M12	M16	M16	M16
D2 H7	13	14	18	22	32	40	50	55	60
D4 h7	63	73	88	108	135	165	205	235	275
D5	31	35	43	53	68	83	104	124	144
D7	21	22	28	33	47	55	75	85	110
D12	62	72	86	106	104	128	160	180	200
D14 h7	63	73	88	108	135	165	205	235	275
D15	62.9	72.9	87	107	105	130	158	178	198
L1	65	75	90	110	140	170	210	240	280
L3	13	14.5	15	15	15	15	20	25	25
L4	2	2	2	2	2	2	2	2	2
L7	47.5	54	62	72	87	102	127	147	167
L11	27	30	36	44	55	67	85	95	110
L13	13	15	15	15	15	15	20	25	25
L21	49	60.5	63	69.5	85.5	95	130	144.5	135
L22	81.5	98	108	124.5	155.5	180	235	264.5	275
L23	40	47	52	53	70	80	95	115	115
L24	30	32	35	35	50	55	65	80	80
C1°	46	70	100	100	130	165	215	215	235
C2°	M4	M5	M6	M6	M8	M10	M12	M12	M12
C3°	≤11 / ≤12 ¹⁰	≤14 / ≤15.875 / ≤16 ¹⁰	≤19	≤24	≤32	≤38	≤42	≤48	≤55
C4°	30	34	40	40	50	60	85	85	116
C5°	30	50	80	80	110	130	180	180	200
C6°	3.5	8	4	4	5	6	6	6	6
C7°	42	60	90	90	115	142	190	190	220
C8°	19.5	19	17	17	19.5	22.5	29	29	63
C9°	133.5	154.5	170	196.5	245	287.5	369	413.5	478
C10°	13.25	13.5	10.75	10.75	13	15	20.75	20.75	53.5
B3 P9	5	5	6	6	10	12	14	16	18
H3	15.3	16.3	20.8	24.8	35.3	43.3	53.8	59.3	64.4

9. C1~C10 are motor specific dimensions (metric std shown).

10. AT065FHM1 offers C3 ≤12 option; AT075FHM1 offers C3 ≤16 option; AT075FHM2 offers C3 ≤15.875 option.

Dimensions (2-stage, Ratio $i=7\sim 50$)

AT-FH / ATB-FH Series

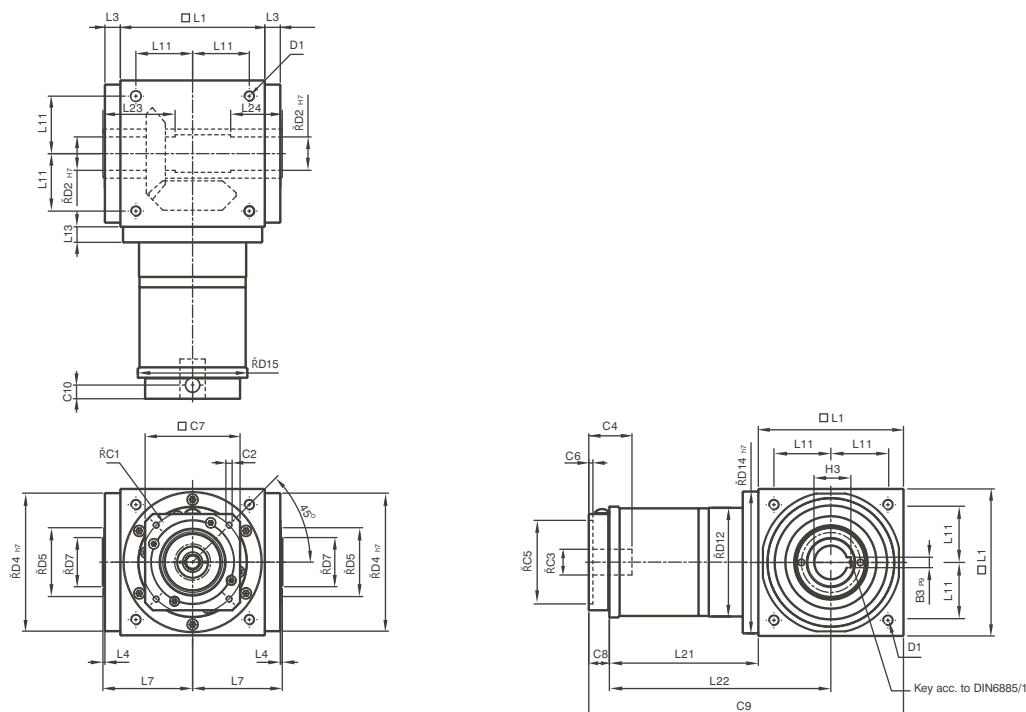

* The dimensions of ATB series are identical to AT series

[unit: mm]

Dimension	AT065FH	AT075FH	AT090FH	AT110FH	AT140FH	AT170FH	AT210FH	AT240FH	AT280FH
D1	M4	M6	M6	M8	M10	M12	M16	M16	M16
D2 _{H7}	13	14	18	22	32	40	50	55	60
D4 _{h7}	63	73	88	108	135	165	205	235	275
D5	31	35	43	53	68	83	104	124	144
D7	21	22	28	33	47	55	75	85	110
D12	62	72	86	106	104	128	160	180	200
D14 _{h7}	63	73	88	108	135	165	205	235	275
D15	62.9	72.9	87	107	106	130	158	178	198
L1	65	75	90	110	140	170	210	240	280
L3	13	14.5	15	15	15	15	20	25	25
L4	2	2	2	2	2	2	2	2	2
L7	47.5	54	62	72	87	102	127	147	167
L11	27	30	36	44	55	67	85	95	110
L13	13	15	15	15	15	15	20	25	25
L21	75	84.5	99	122	144.5	157.5	206.5	239	248
L22	107.5	122	144	177	214.5	242.5	311.5	359	388
L23	40	47	52	53	70	80	95	115	115
L24	30	32	35	35	50	55	65	80	80
C1 ¹¹	46	46	70	100	100	100	130	165	165
C2 ¹¹	M4	M4	M5	M6	M6	M6	M8	M10	M10
C3 ¹¹	≤12	≤12	≤16	≤24	≤24	≤24	≤32	≤38	≤38
C4 ¹¹	30	30	34	40	40	40	50	60	60
C5 ¹¹	30	30	50	80	80	80	110	130	130
C6 ¹¹	3.5	3.5	8	4	4	4	5	6	6
C7 ¹¹	42	42	60	92	92	92	115	142	142
C8 ¹¹	21.5	21.5	21.5	20	20	20	24	31	31
C9 ¹¹	161.5	181	210.5	252	304.5	347.5	440.5	510	559
C10 ¹¹	14.5	14.5	15.5	13	13	13	16	21	21
B3 _{P9}	5	5	6	6	10	12	14	16	18
H3	15.3	16.3	20.8	24.8	35.3	43.3	53.8	59.3	64.4

11. C1~C10 are motor specific dimensions (metric std shown).

Dimensions (3-stage, Ratio $i=75\sim 500$) AT-FH / ATB-FH Series

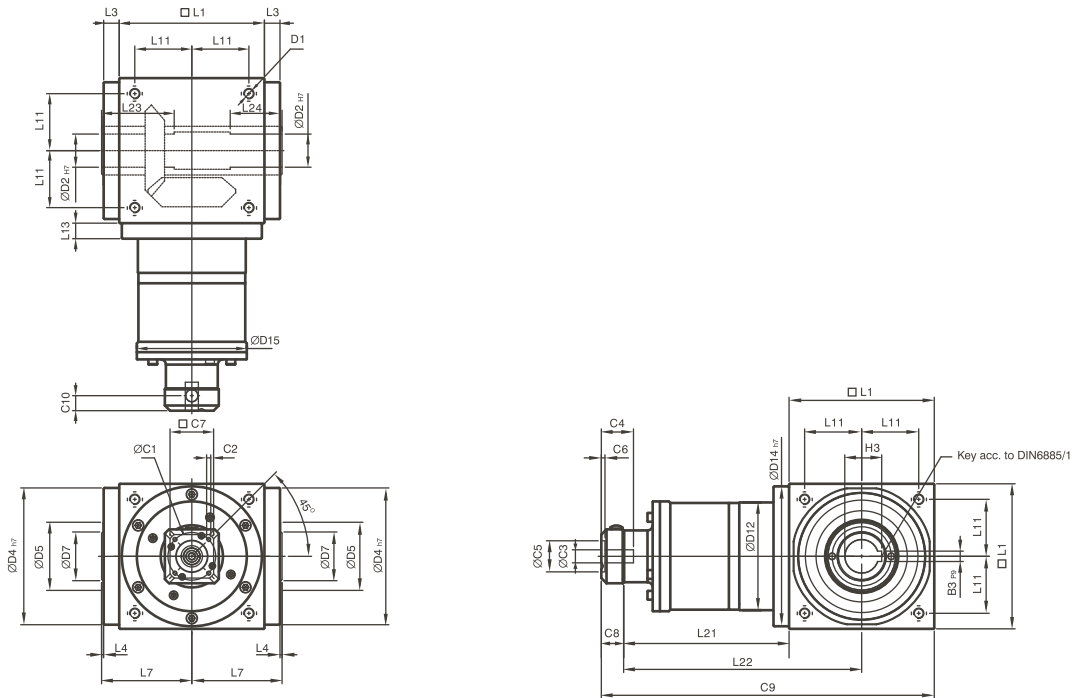

* The dimensions of ATB series are identical to AT series.

[unit: mm]

Dimension	AT110FH	AT140FH	AT170FH	AT210FH	AT240FH	AT280FH
D1	M8	M10	M12	M16	M16	M16
D2 _{H7}	22	32	40	50	55	60
D4 _{h7}	108	135	165	205	235	275
D5	53	68	83	104	124	144
D7	33	47	55	75	85	110
D12	106	104	128	160	180	200
D14 _{h7}	108	135	165	205	235	275
D15	107	106	130	158	178	198
L1	110	140	170	210	240	280
L3	15	15	15	20	25	25
L4	2	2	2	2	2	2
L7	72	87	102	127	147	167
L11	44	55	67	85	95	110
L13	15	15	15	20	25	25
L21	136.5	159.5	183.5	226	269	278
L22	191.5	229.5	268.5	331	389	418
L23	53	70	80	95	115	115
L24	35	50	55	65	80	80
C1 ¹²	46	46	70	70	100	100
C2 ¹²	M4	M4	M5	M5	M6	M6
C3 ¹²	≤12	≤12	≤16	≤16	≤24	≤24
C4 ¹²	30	30	34	34	40	40
C5 ¹²	30	30	50	50	80	80
C6 ¹²	3.5	3.5	8	8	4	4
C7 ¹²	42	42	60	60	92	92
C8 ¹²	21.5	21.5	21.5	21.5	20	20
C9 ¹²	268	321	375	457.5	529	578
C10 ¹²	14.5	14.5	15.5	15.5	13	13
B3 _{P9}	6	10	12	14	16	18
H3	24.8	35.3	43.3	53.8	59.3	64.4

12. C1~C10 are motor specific dimensions (metric std shown).

Dimensions (1-stage, Ratio $i=1\sim5$) AT-FC / ATB-FC Series

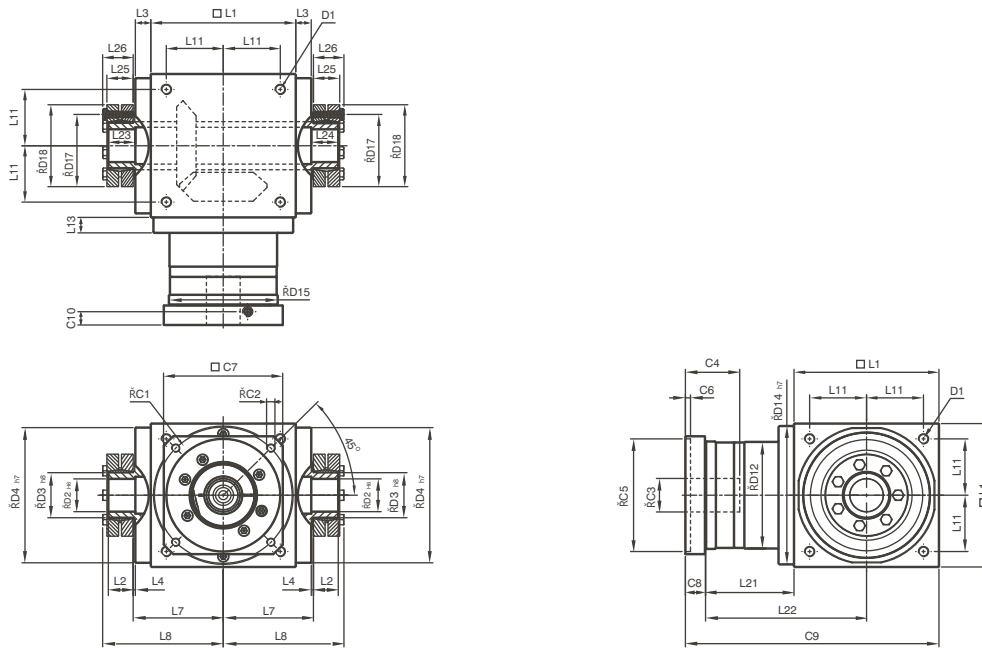

* The dimensions of ATB series are identical to AT series.

[unit: mm]

Dimension	AT065FC	AT075FC	AT090FC	AT110FC	AT140FC	AT170FC	AT210FC	AT240FC	AT280FC
D1	M4	M6	M6	M8	M10	M12	M16	M16	M16
D2 H6	13	14	18	22	32	40	50	55	60
D3 h8	16	16	22	25	44	50	62	68	75
D4 h7	63	73	88	108	135	165	205	235	275
D12	62	72	86	106	104	128	160	180	200
D14 h7	63	73	88	108	135	165	205	235	275
D15	62.9	72.9	87	107	105	130	158	178	198
D17	26	26	36	38	61	70	86	86	100
D18	41	41	50	50	80	90	110	115	138
L1	65	75	90	110	140	170	210	240	280
L2	14	14	18	18	24	26	29	29	30.5
L3	13	14.5	15	15	15	15	20	25	25
L4	2	2	2	2	2	2	2	2	2
L7	47.5	54	62	72	87	102	127	147	167
L8	66	72.5	85	95	116.5	133.5	161.5	181.5	205
L11	27	30	36	44	55	67	85	95	110
L13	13	15	15	15	15	15	20	25	25
L21	49	60.5	63	69.5	85.5	95	130	144.5	135
L22	81.5	98	108	124.5	155.5	180	235	264.5	275
L23	15	15	20	20	26	28	31	31	32.5
L24	15	15	20	20	26	28	31	31	32.5
L25	15	15	19.5	19.5	25.5	27.5	30.5	30.5	32.5
L26	18.5	18.5	23	23	29.5	31.5	34.5	34.5	38
C1 ¹³	46	70	100	100	130	165	215	215	235
C2 ¹³	M4	M5	M6	M6	M8	M10	M12	M12	M12
C3 ¹³	≤11 / ≤12 ¹⁴	≤14 / ≤15.875 / ≤16 ¹⁴	≤19	≤24	≤32	≤38	≤42	≤48	≤55
C4 ¹³	30	34	40	40	50	60	85	85	116
C5 ¹³	30	50	80	80	110	130	180	180	200
C6 ¹³	3.5	8	4	4	5	6	6	6	6
C7 ¹³	42	60	90	90	115	142	190	190	220
C8 ¹³	19.5	19	17	17	19.5	22.5	29	29	63
C9 ¹³	133.5	154.5	170	196.5	245	287.5	369	413.5	478
C10 ¹³	13.25	13.5	10.75	10.75	13	15	20.75	20.75	53.5

13. C1-C10 are motor specific dimensions (metric std shown).

14. AT065FCM1 offers C3 ≤12 option; AT075FCM1 offers C3 ≤16 option; AT075FCM2 offers C3 ≤15.875 option.

Dimensions (2-stage, Ratio $i=7\sim 50$) AT-FC / ATB-FC Series

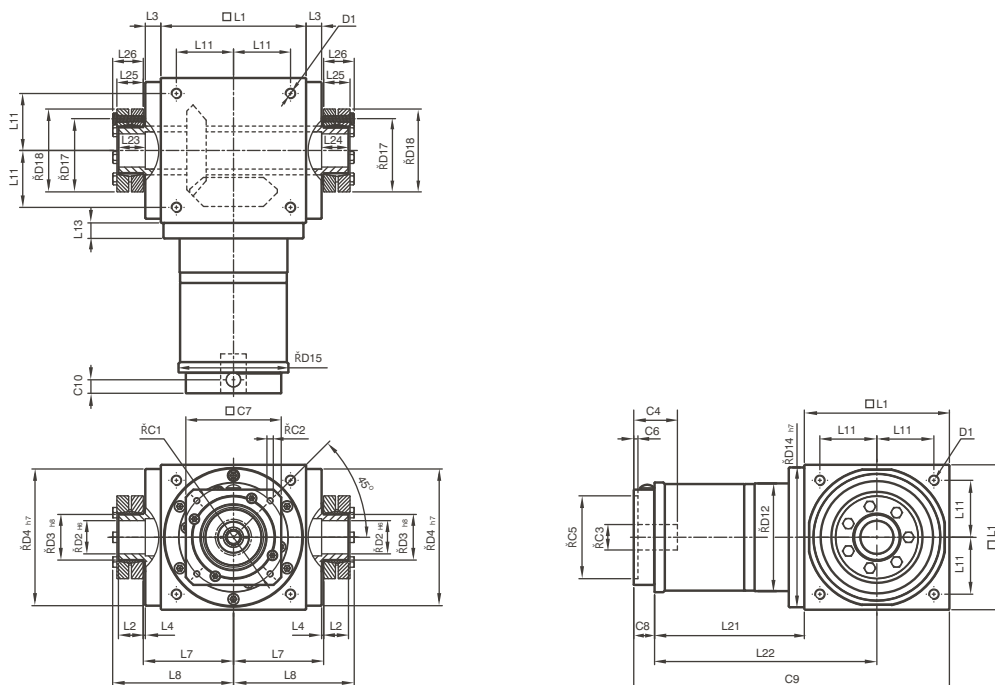

* The dimensions of ATB series are identical to AT series.

[unit: mm]

Dimension	AT065FC	AT075FC	AT090FC	AT110FC	AT140FC	AT170FC	AT210FC	AT240FC	AT280FC
D1	M4	M6	M6	M8	M10	M12	M16	M16	M16
D2 H6	13	14	18	22	32	40	50	55	60
D3 h8	16	16	22	25	44	50	62	68	75
D4 h7	63	73	88	108	135	165	205	235	275
D12	62	72	86	106	104	128	160	180	200
D14 h7	63	73	88	108	135	165	205	235	275
D15	62.9	72.9	87	107	106	130	158	178	198
D17	26	26	36	38	61	70	86	86	100
D18	41	41	50	50	80	90	110	115	138
L1	65	75	90	110	140	170	210	240	280
L2	14	14	18	18	24	26	29	29	30.5
L3	13	14.5	15	15	15	15	20	25	25
L4	2	2	2	2	2	2	2	2	2
L7	47.5	54	62	72	87	102	127	147	167
L8	66	72.5	85	95	116.5	133.5	161.5	181.5	205
L11	27	30	36	44	55	67	85	95	110
L13	13	15	15	15	15	15	20	25	25
L21	75	84.5	99	122	144.5	157.5	206.5	239	248
L22	107.5	122	144	177	214.5	242.5	311.5	359	388
L23	15	15	20	20	26	28	31	31	32.5
L24	15	15	20	20	26	28	31	31	32.5
L25	15	15	19.5	19.5	25.5	27.5	30.5	30.5	32.5
L26	18.5	18.5	23	23	29.5	31.5	34.5	34.5	38
C1 ¹⁵	46	46	70	100	100	100	130	165	165
C2 ¹⁵	M4	M4	M5	M6	M6	M6	M8	M10	M10
C3 ¹⁵	≤12	≤12	≤16	≤24	≤24	≤24	≤32	≤38	≤38
C4 ¹⁵	30	30	34	40	40	40	50	60	60
C5 ¹⁵	30	30	50	80	80	80	110	130	130
C6 ¹⁵	3.5	3.5	8	4	4	4	5	6	6
C7 ¹⁵	42	42	60	92	92	92	115	142	142
C8 ¹⁵	21.5	21.5	21.5	20	20	20	24	31	31
C9 ¹⁵	161.5	181	210.5	252	304.5	347.5	440.5	510	559
C10 ¹⁵	14.5	14.5	15.5	13	13	13	16	21	21

15. C1~C10 are motor specific dimensions (metric std shown).

Dimensions (3-stage, Ratio $i=75\sim 500$)

AT-FC / ATB-FC Series

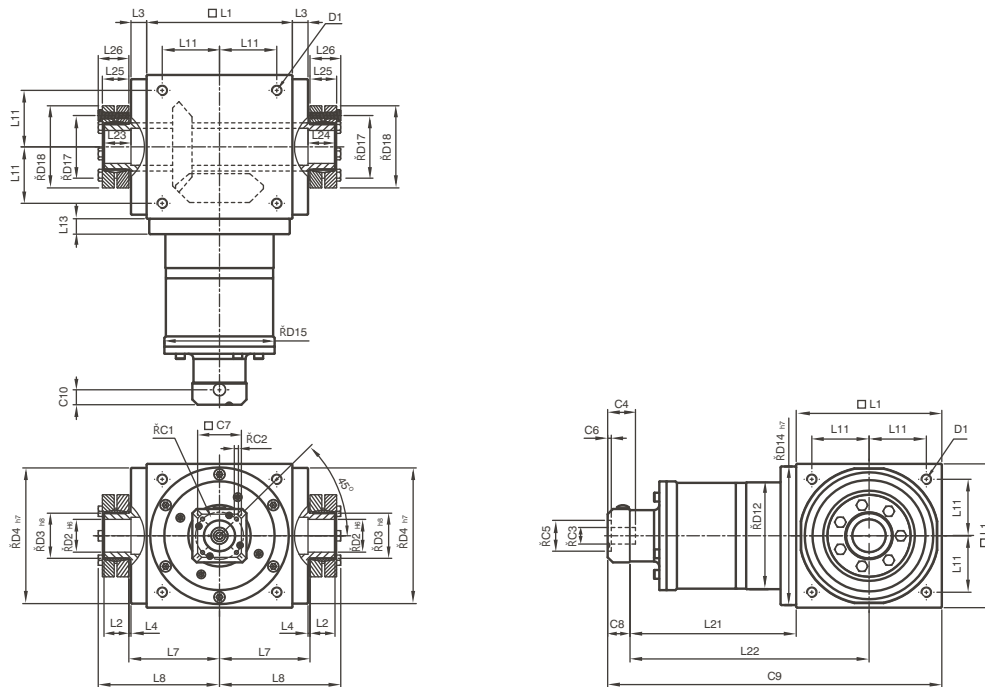

* The dimensions of ATB series are identical to AT series.

[unit: mm]

Dimension	AT110FC	AT140FC	AT170FC	AT210FC	AT240FC	AT280FC
D1	M8	M10	M12	M16	M16	M16
D2 ^{H6}	22	32	40	50	55	60
D3 ^{h8}	25	44	50	62	68	75
D4 ^{h7}	108	135	165	205	235	275
D12	106	104	128	160	180	200
D14 ^{h7}	108	135	165	205	235	275
D15	107	106	130	158	178	198
D17	38	61	70	86	86	100
D18	50	80	90	110	115	138
L1	110	140	170	210	240	280
L2	18	24	26	29	29	30.5
L3	15	15	15	20	25	25
L4	2	2	2	2	2	2
L7	72	87	102	127	147	167
L8	95	116.5	133.5	161.5	181.5	205
L11	44	55	67	85	95	110
L13	15	15	15	20	25	25
L21	136.5	159.5	183.5	226	269	278
L22	191.5	229.5	268.5	331	389	418
L23	20	26	28	31	31	32.5
L24	20	26	28	31	31	32.5
L25	19.5	25.5	27.5	30.5	30.5	32.5
L26	23	29.5	31.5	34.5	34.5	38
C1 ¹⁶	46	46	70	70	100	100
C2 ¹⁶	M4	M4	M5	M5	M6	M6
C3 ¹⁶	≤12	≤12	≤16	≤16	≤24	≤24
C4 ¹⁶	30	30	34	34	40	40
C5 ¹⁶	30	30	50	50	80	80
C6 ¹⁶	3.5	3.5	8	8	4	4
C7 ¹⁶	42	42	60	60	92	92
C8 ¹⁶	21.5	21.5	21.5	21.5	20	20
C9 ¹⁶	268	321	375	457.5	529	578
C10 ¹⁶	14.5	14.5	15.5	15.5	13	13

16. C1~C10 are motor specific dimensions (metric std shown).

Selection of the Optimum Gearbox

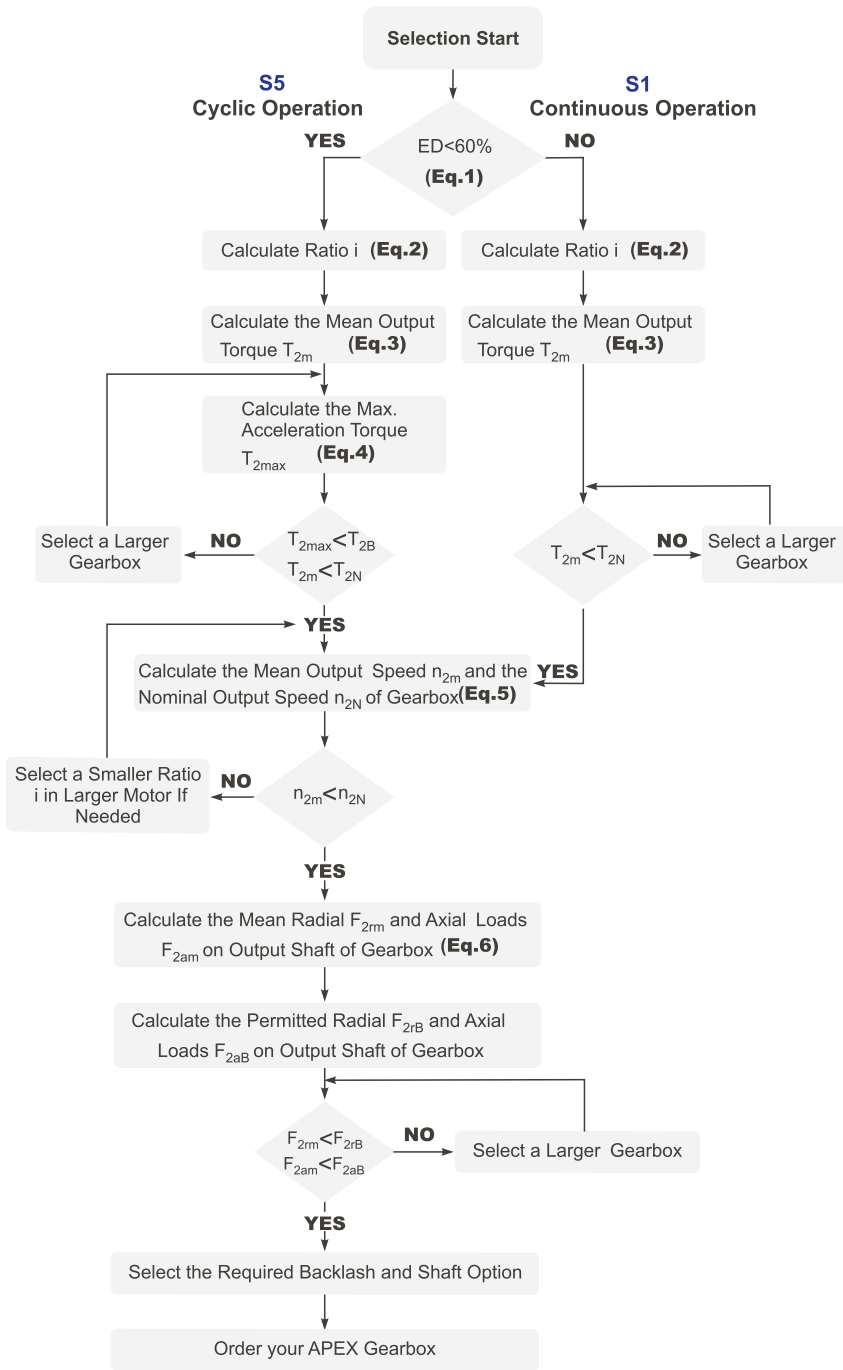

Recommended (for S5 Cycle Operation)

The general design is given for

$$\frac{J_L}{i^2} \leq 4 \times J_m$$

The optimal design is given for

$$\frac{J_L}{i^2} \cong J_m$$

J_L Load Inertia

J_m Motor Inertia

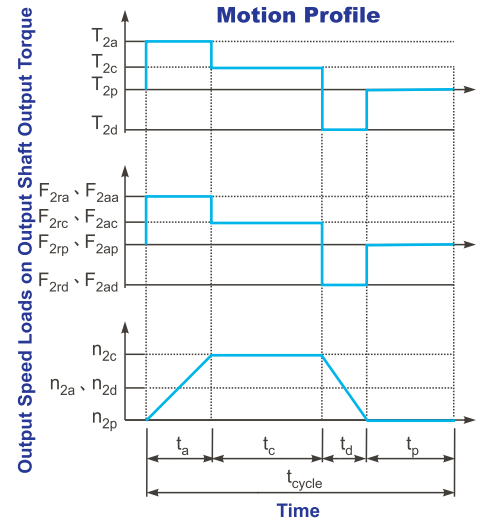

$$1. ED = \frac{t_a + t_c + t_d}{t_{cycle}} \times 100\% .$$

Index : a. Acceleration, c. Constant,
d. Deceleration, p. Pause **(Eq.1)**

$$2. i \cong \frac{n_m}{n_{work}}$$

n_m Output Speed of the Motor
 n_{work} Working Speed **(Eq.2)**

$$3. T_{2m} = 3 \sqrt{\frac{n_{2a} \times t_a \times T_{2a}^3 + n_{2c} \times t_c \times T_{2c}^3 + n_{2d} \times t_d \times T_{2d}^3}{n_{2a} \times t_a + n_{2c} \times t_c + n_{2d} \times t_d}}$$

(Eq.3)

4. $T_{2max} = T_{mB} \times i \times K_s \times \eta$

where K_s is

K_s	No. of Cycles / hr
1.0	0 ~ 1,000
1.1	1,000 ~ 1,500
1.3	1,500 ~ 2,000
1.6	2,000 ~ 3,000
1.8	3,000 ~ 5,000

T_{mB} Max. Output Torque of the Motor
 η Efficiency of the Gearbox **(Eq.4)**

$$5. n_{2a} = n_{2d} = \frac{1}{2} \times n_{2c}$$

$$n_{2m} = \frac{n_{2a} \times t_a + n_{2c} \times t_c + n_{2d} \times t_d}{t_a + t_c + t_d}$$

$$n_{2N} = \frac{n_{1N}}{i}$$

(Eq.5)

$$6. F_{2rm} = 3 \sqrt{\frac{n_{2a} \times t_a \times F_{2ra}^3 + n_{2c} \times t_c \times F_{2rc}^3 + n_{2d} \times t_d \times F_{2rd}^3}{n_{2a} \times t_a + n_{2c} \times t_c + n_{2d} \times t_d}}$$

$$F_{2am} = 3 \sqrt{\frac{n_{2a} \times t_a \times F_{2aa}^3 + n_{2c} \times t_c \times F_{2ac}^3 + n_{2d} \times t_d \times F_{2ad}^3}{n_{2a} \times t_a + n_{2c} \times t_c + n_{2d} \times t_d}}$$

(Eq.6)

Permitted Radial and Axial Loads

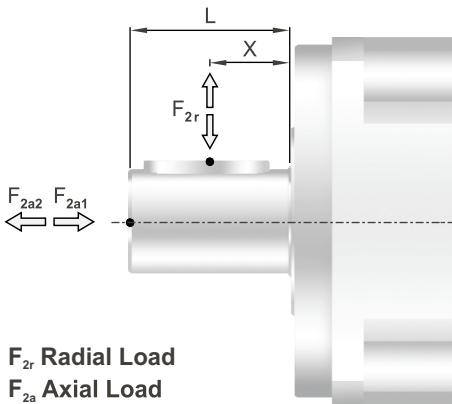

The permitted radial and axial loads on output shaft of the gearbox depend on the design of the gearbox supporting bearings.

LUDE use the extension straddle oversized ball bearing design. It can take heavy load from both axes.

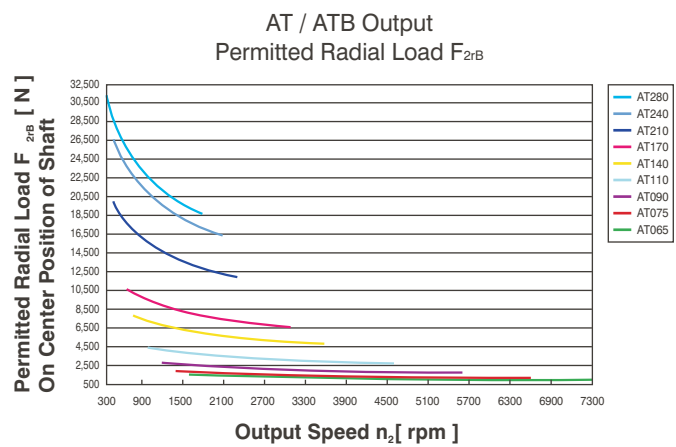
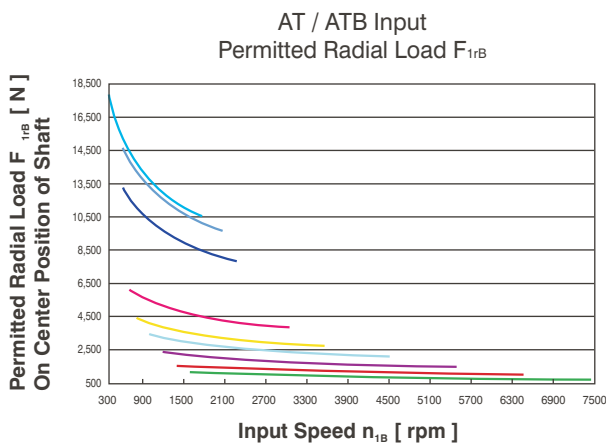

If radial force F_{2r} is exert on the center of the output shaft $X=1/2 \times L$.
 The permitted radial load is given on left diagram.

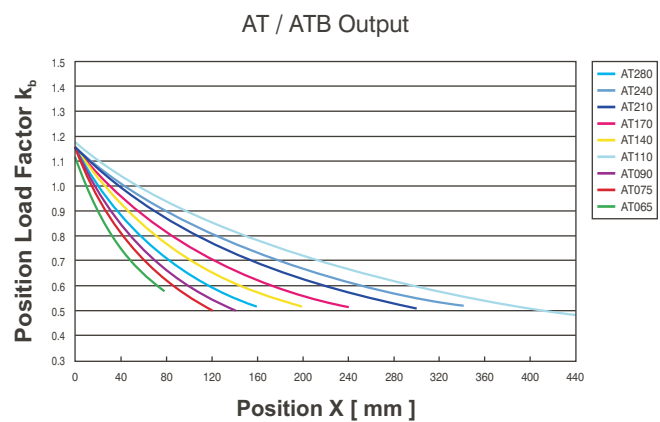
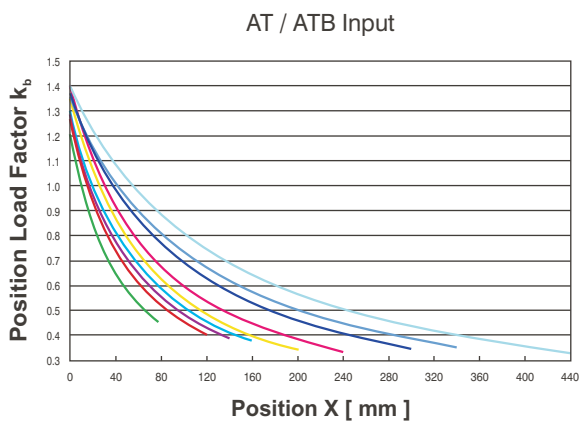

If radial force F_{2r} is not exert on the center of the output shaft $X < 1/2 \times L$ or $X > 1/2 \times L$
 The permitted radial and axial loads can be calculated by the position load factor K_b on the left diagram.



Dezhou Lude Transmission Equipments CO.,LTD

NO.2758 Mengyin Road, Economic&Technical Development Zone, Dezhou, Shandong, China

TEL: 0086-534-2765998 2761998

E-mail: ludetransmission@gmail.com china@ludetransmission.com

Web: www.ludetransmission.com